





目录	页面	Contents	Page
<b>NMRV系列蜗轮减速机</b>		<b>NMRV series worm gear reducer</b>	
产品外形	21-21	Products Figure	21-21
型号标记	22-22	Designation	22-22
电机配置说明	22-23	Configuration	22-23
安装位置	24-26	Mounting Position	24-26
技术参数	26-55	Technical Data	26-55
安装尺寸	56-76	Mounting Dimensions	56-76



产品外形

Products Figure

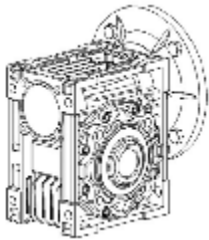

**NMRV**

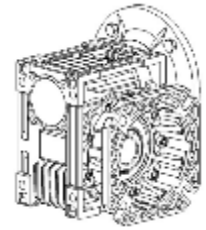

**NMRV  
F**

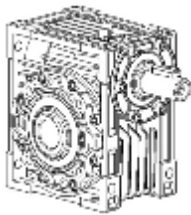

**NRV**

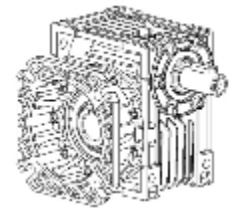

**NRV  
F**

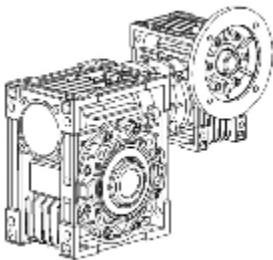

**NMRV-NMRV**

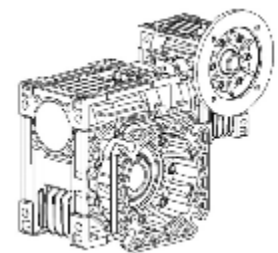

**NMRV-NMRV  
F**

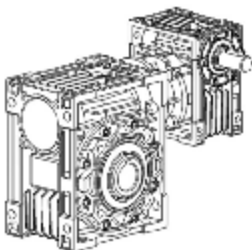

**NRV-NMRV**

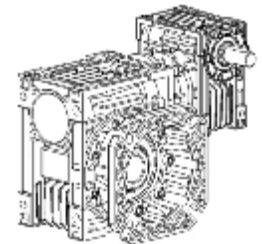

**NRV-NMRV  
F**

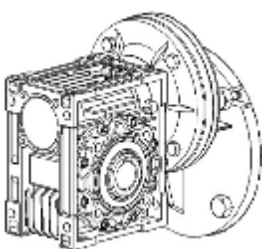

**PC-NMRV**

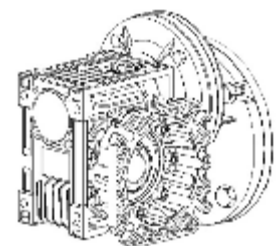

**PC-NMRV  
F**



## 型号标记

## Designation

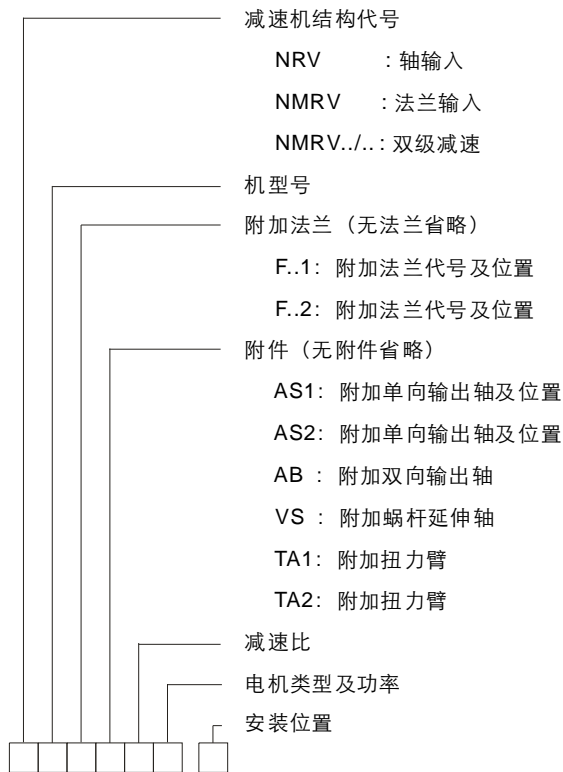

gear unit type

- NRV :with input shaft
- NMRV : with input flange
- NMRV../..: double stage

gear unit size

- with flange (omit without flange)
- F..1: with output flange F..1,at position 1
- F..2: with output flange F..2,at position 2

with fitting parts (omit when no fitting part)

- AS1: with single output shaft at position 1
- AS2: with single output shaft at position 2
- AB : with double output shaft
- VS : with extention input shaft
- TA1: with torque arm at position 1
- TA2: with torque arm at position 2

transmission ratio

electric motor type and power

mounting position

### 标记示例

- A NRV040-50-B3  
轴输入, 机型号040, 速比50, 安装位置B3
- B NMRV050-FA1-15-Y0.75-B5  
带法兰输入, 机型号050, 带输出法兰FA1, 速比15, Y系列标准电机, 电机功率0.75KW, 安装位置B5
- C NMRV110-TA1-25-YB2.2-B5 (dII BT4,IP54/F)  
带法兰输入, 机型号110,带转矩臂TA1, 速比25, 防爆电机YB100L1-4, 防爆等级dII BT4, 防护等级IP54 绝缘等级F, 安装位置B5

### Sign Example

- A NRV040-50-B3  
input shaft, gear unit size 040, ratio50, mounting position B3
- B NMRV050-FA1-15-Y0.75-B5  
input with flange, gear unit size 050 with additional output flange FA1, ratio15; Y series standard motor, motor power 0.75KW, mounting positionB5
- C NMRV110-25-TA1-YB2.2-B5 (dII BT4,IP54/F)  
input with flange, gear unit size 110 with additional torque arm TA1, ratio25; Y series explosion proof motor, power 2.2KW,(dII BT4,IP54/F), mounting positionB5

## 电机配置说明

## Configuration of Electric Motor

### Y系列普通三相异步电机

### Y series Three-phase Asynchronous Electric Motor

- 1 本系列减速机标准配置Y系列普通三相异步感应电机;
- 2 电机电压: 380V/50Hz;
- 3 电机防护等级IP54, 绝缘等级F, B级温升;
- 4 环境温度不超过40℃,不低于-15℃;
- 5 连续工作制S1;
- 6 海拔高度不超过1000m;

- 1 this NMRV series gear unit configure three-phase asynchronous electric motor;
- 2 voltage:380V/50Hz;
- 3 protection class:IP54,insulation class: F; temperature rising class: B;
- 4 ambient temperature:-15~40℃ ;
- 5 continue working duty:S1;
- 6 altitude less than 1000m;



## 电机配置说明

## Configuration of Electric Motor

### Y系列普通三相异步电机

- 冷却方式为C0141（风扇自冷）；
- 100L2及以下规格为"Y"接法，112M及以上规格为"Δ"接法；
- 优先选用 4, 6, 8极电机，2极电机不推荐使用；
- 电机技术参数见第189-194页

### YEJ系列三相异步制动电机

- 三相异步制动电机为普通电机的基础上附加制动器；
- 电机电压：380V/50Hz；
- 制动器电压：规格71~100: DC99V  
规格112~200: DC170V
- 配置单相AC220/50Hz整流器；
- 电机防护等级IP44，绝缘等级F, B级温升；
- 环境温度不超过40℃,不低于-15℃；
- 连续工作制S1；
- 海拔高度不超过1000m；
- 冷却方式为C0141（风扇自冷）；
- 100及以下规格为"Y"接法，112M及以上规格为"Δ"接法；
- 优先选用 4, 6, 8极电机，2极电机不推荐使用。
- 电机技术参数见第189-194页

### YVF系列三相异步变频电机

- 电机电压：380V；
- 基准频率：50Hz；
- 允许调频5~50Hz，恒转矩调速；
- 电机防护等级IP54，绝缘等级F, B级温升；
- 环境温度不超过40℃,不低于-15℃；
- 连续工作制S1；
- 海拔高度不超过1000m；
- 冷却方式为C416（独立风扇）；
- 接线方式按适配变频器要求；
- 优先选用 4极电机。

### 特殊电机

- 选用包括防爆电机，辊道电机，船用电机，多速电机等特殊电机，  
本公司提供IEC标准电机法兰接口，接口尺寸见76页；
- 异频率，异电压电机，请联系本公司技术部；
- 使用环境温度不在-15~40℃范围内，请联系本公司技术部；
- 更高的绝缘等级及防护等级，请联系本公司技术部。

### Y series Three-phase Asynchronous Electric Motor

- self-cooling with fan:C0141；
- within frame 100, follow connection Y, from frame 112, follow connection Δ；
- first select 4,6,8 poles motor；
- technical data on page 189-194.

### YEJ series Three-phase Asynchronous Brake Motor

- base on Y series motor, add a brake.
- voltage:380V/50Hz；
- brake voltage: frame:71~100 DC99V  
frame:112~200 DC170V；
- with single phase AC220V/50Hz rectifier；
- protection class:IP54,insulation class: F, temperature rising class: B；
- ambient temperature:-15~40℃；
- continue working duty:S1；
- altitude less than 1000m；
- self-cooling with fan:C0141；
- within frame 100, follow connection Y, from frame 112, follow connection Δ；
- first select 4,6,8 poles motor；
- technical data on page 189-194.

### YVF series Three-phase Variable-frequency Motor

- voltage:380V；
- rated frequency 50Hz；
- available frequency:5~50Hz；
- protection class:IP54,insulation class: F, temperature rising class:B；
- ambient temperature:-15~40℃；
- continue working duty:S1；
- altitude less than 1000m；
- cooling with independence fan:C416；
- connection perform the requirement of inverter；
- first select 4 poles motor；

### Customized Motor

- others like explosion proof, roller motor, marine motor or multi-speed motor coupled by adaptor, the dimensions on page 76.
- need different frequency and voltage, please contact us.
- ambient temperature is not in -15~40℃, please contact us.
- for higher insulation and protection class, please contact us.



附加配件及位置

With fitting Parts and Position

附加输出法兰及位置

With output flange and positions



附加单向输出轴及位置

With single output shaft and positions

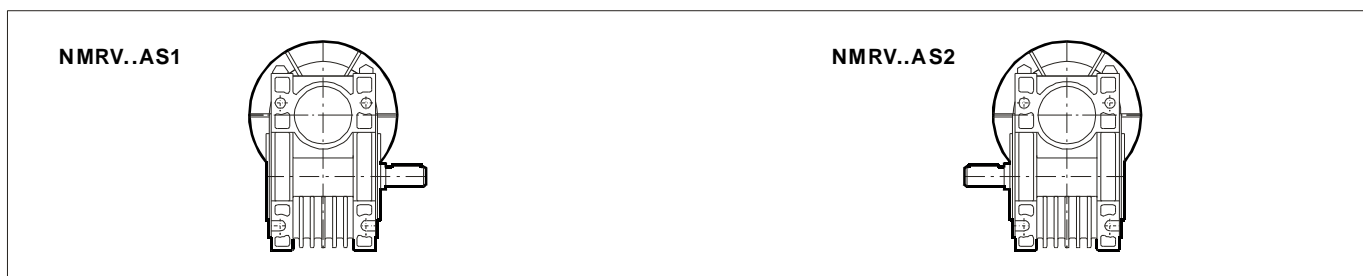

附加扭力臂及位置

With torque arm and positions



附加双向输出轴  
附加蜗杆延伸轴

With double output shaft  
With worm extensional shaft

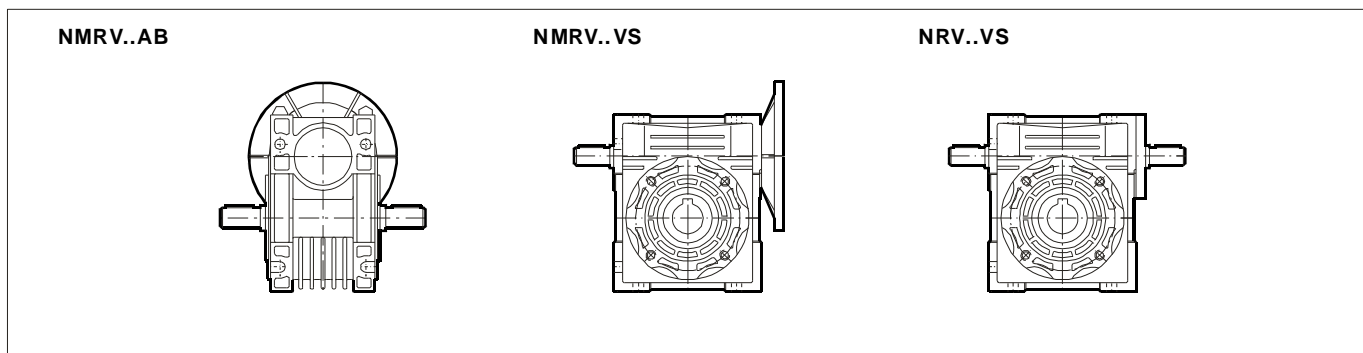



安装位置

Mounting Position

NRV...,NMRV...,NMRV+PC..减速机安装位置

Mounting Position for NRV...,NMRV...,NMRV+PC..

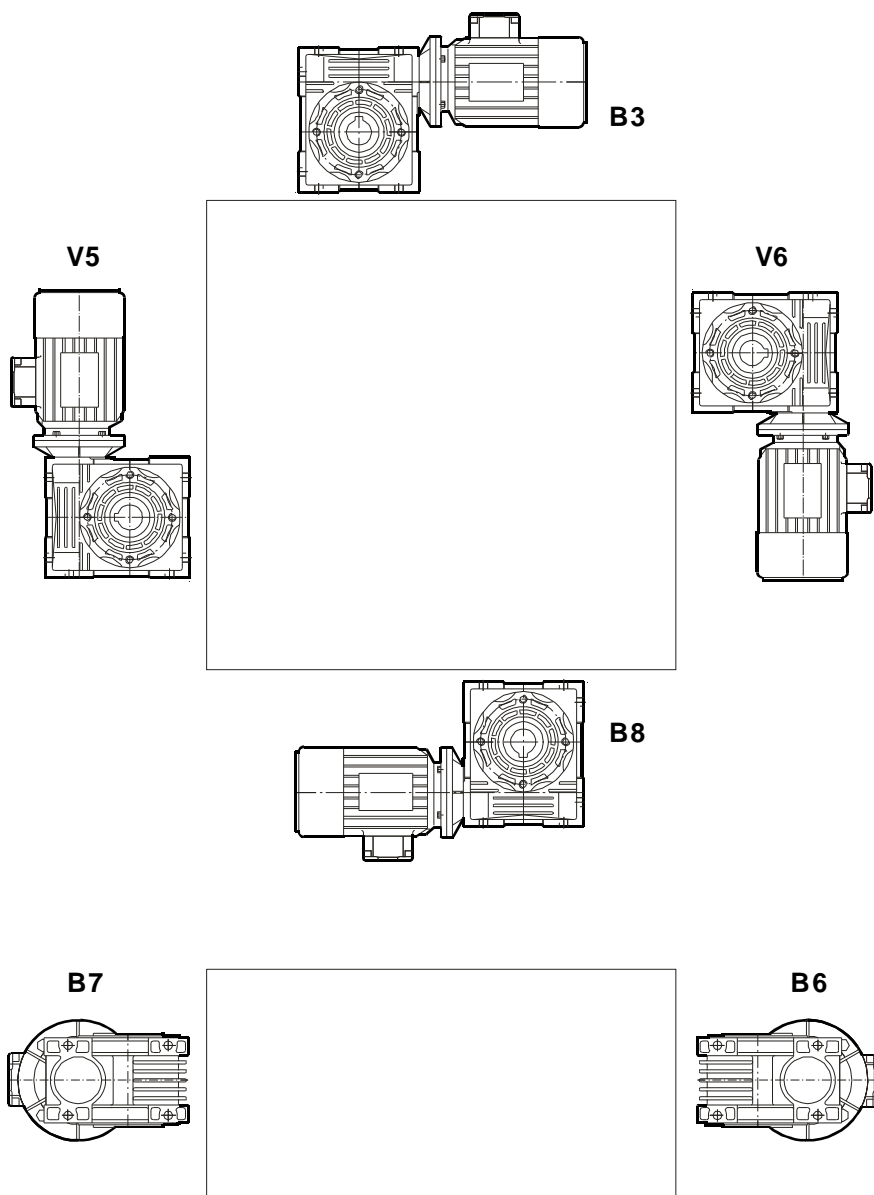

接线盒位置

Terminal Box Position

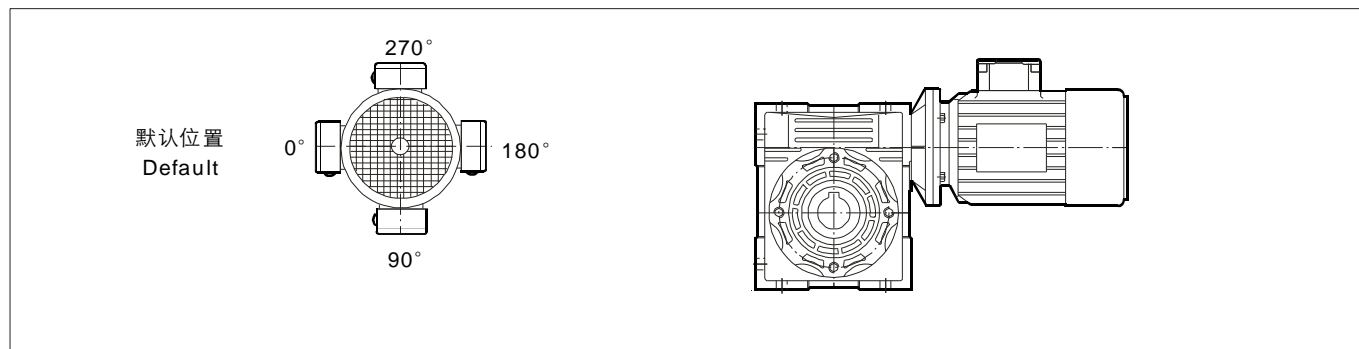



## 安装位置

## Mounting Position

双级减速机安装位置

Double Stage Worm gear Reducer Mounting Position

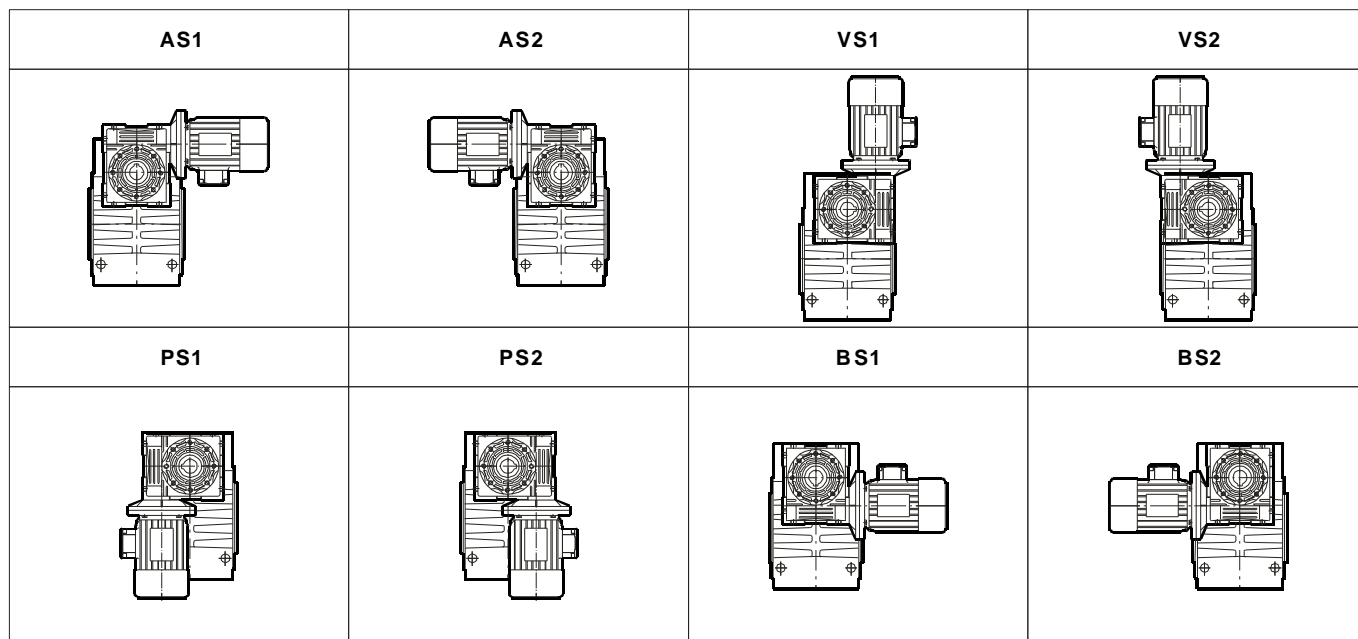

## 技术参数

## Technical Data

符号意义

Key to Symbols



**$P_1 = 0.06KW$**

Na rpm	M <sub>2</sub> Nm	i	Fr <sub>2MAX</sub> [N]	f <sub>s</sub>	Type	Gear unit	Motor size	 Kg
280	1.8	5	439	6.2	NMRV	025	5614	3.7
186.7	2.6	7.5	503	4.2				
140	3.4	10	553	3.5				
93.3	4.9	15	633	2.5				



- 1 电机功率
- 2 输出转速
- 3 输出转矩
- 4 减速比
- 5 输出轴中最大点载荷
- 6 使用系数
- 7 减速机类型
- 8 减速机规格
- 9 电机型号
- 10 大概重量

- 1 motor power
- 2 output speed
- 3 output torque
- 4 transmission ratio
- 5 maximum load on middle output shaft
- 6 service factor
- 7 gear unit type
- 8 gear unit size
- 9 motor frame
- 10 approximate weight





技术参数

Technical Data

P <sub>1</sub> = 0.06 KW								
Na rpm	M <sub>2</sub> Nm	i	Fr <sub>2</sub> MAX [N]	f <sub>s</sub>	Type	Gear unit	Motor size	 Kg
280	1.8	5	439	6.2	NMRV	025	5614	3.7
186.7	2.6	7.5	503	4.2				
140	3.4	10	553	3.5				
93.3	4.9	15	633	2.5				
70	6.1	20	697	2				
46.7	8.2	30	798	1.6				
35	10	40	878	1.3				
28	12	50	946	0.9				
23.3	14	60	1003	0.7				
280	1.8	5	597	10.1	NMRV	030	5614	4.2
186.7	2.6	7.5	683	6.9				
140	3.4	10	752	5.4				
93.3	4.7	15	861	3.8				
70	6	20	948	3				
56	7	25	1021	3				
46.7	8	30	1085	2.5				
35	9.7	40	1194	1.9				
28	11	50	1286	1.5				
23.3	13	60	1367	1.3				
17.5	14	80	1504	0.9				
14	25	100	1620	1.3	NMRV	025/030	5614	4.9
9.3	32	150	1830	0.9				
7	41	200	1830	0.7				
5.6	44	250	1830	0.8				
4.7	59	300	3490	1.2	NMRV	025/040	5614	6.0
3.5	71	400	3490	0.9				
2.8	82	500	3490	0.7				
2.3	101	600	3490	0.6				
1.9	116	750	3490	0.5				
1.6	143	900	3490	0.5				
1.2	171	1200	3490	0.4	NMRV	025/040	5614	6.0
0.9	197	1500	3490	0.3				
0.8	217	1800	3490	0.3				
0.6	268	2400	3490	0.2				
0.5	324	3000	3490	0.2				
0.4	294	4000	3490	0.1				
0.3	356	5000	3490	0.1				
4.7	57	300	3490	1.3	NMRV	030/040	5614	6.5
3.5	70	400	3490	0.9				
2.8	96	500	3490	0.6				
2.3	104	600	3490	0.7				
1.9	121	750	3490	0.6				

**技术参数****Technical Data****P<sub>1</sub> = 0.06 KW**

N <sub>A</sub> rpm	M <sub>2</sub> Nm	i	Fr <sub>2</sub> MAX[N]	f <sub>s</sub>	Type	Gear unit	Motor size	Kg
1.6	139	900	3490	0.5	NMRV	030/040	5614	6.5
1.2	166	1200	3490	0.4				
0.9	196	1500	3490	0.4				
0.8	218	1800	3490	0.3				
0.58	261	2400	3490	0.2				
0.4	300	3200	3490	0.2				
0.4	279	4000	3490	0.1				
0.28	338	5000	3490	0.1				
1.6	141	900	4840	1.0	NMRV	030/050	5614	7.7
1.2	169	1200	4840	0.7				
0.93	199	1500	4840	0.7				
0.78	222	1800	4840	0.7				
0.6	266	2400	4840	0.5				
0.5	307	3000	4840	0.4				
0.35	288	4000	4840	0.3				
0.29	311	4800	4840	0.3				
0.9	204	1500	6270	1.1	NMRV	030/063	5614	10.4
0.78	225	1800	6270	0.9				
0.58	276	2400	6270	0.8				
0.47	319	3000	6270	0.7				
0.35	306	4000	6270	0.6				
0.28	360	5000	6270	0.4				
0.6	330	2400	7380	1.1	NMRV	040/075	5614	14.3
0.47	377	3000	7380	0.8				
0.35	355	4000	7380	0.7				
0.28	419	5000	7380	0.5				
0.5	406	3000	8180	1.4	NMRV	040/090	5614	18.3
0.35	365	4000	8180	1.3				
0.28	431	5000	8180	1.0				

**P<sub>1</sub> = 0.09 KW**

560	1.4	5	349	5.9	NMRV	025	5612	3.5
373.3	2.0	7.5	399	3.9				
280	2.6	10	439	3.4				
186.7	3.8	15	503	2.4				
140	4.9	20	553	1.9				
93.3	6.7	30	633	1.3				
70	8.3	40	697	1.1				
56	10	50	751	0.9				



### 技术参数

### Technical Data

P <sub>1</sub> = 0.09 KW								
NA rpm	M <sub>2</sub> Nm	i	Fr <sub>2</sub> MAX[N]	f <sub>s</sub>	Type	Gear unit	Motor size	 Kg
280	2.7	5	439	4.1	NMRV	025	5624	4.0
186.7	3.9	7.5	503	2.8				
140	5.1	10	553	2.4				
93.3	7.3	15	633	1.6	NMRV	025	5624	4.0
70	9.2	20	697	1.3				
46.7	12	30	798	1.1				
35	15	40	878	0.9				
560	1.4	5	474	8.8	NMRV	030	5612	4.0
373.3	2.0	7.5	542	6.5				
280	2.6	10	597	5.0				
186.7	3.7	15	683	3.5				
140	4.8	20	752	2.5				
112	5.7	25	810	2.8				
93.3	6.5	30	861	2.3				
70	8.1	40	948	1.7				
56	10	50	1021	1.4				
46.7	11	60	1085	1.1				
35	13	80	1194	0.9				
280	2.7	5	597	6.7	NMRV	030	5624	4.0
186.7	3.9	7.5	683	4.6				
140	5.0	10	752	3.6				
93.3	7.1	15	861	2.5				
70	9.0	20	948	2.0				
56	10	25	1021	2.0				
46.7	12	30	1085	1.7				
35	14	40	1194	1.2				
28	17	50	1286	1.0				
23.3	19	60	1367	0.9				
180	4.1	5	692	4.9				
120	5.9	7.5	792	3.4				
90	7.6	10	871	2.6				
60	11	15	997	1.9				
45	13	20	1098	1.5				
36	15	25	1183	1.5				
30	17	30	1257	1.2				
22.5	21	40	1383	1.0	NMRV	030	63M1-6	5.4
18	24	50	1490	0.7				



技术参数

Technical Data

P <sub>1</sub> = 0.09 KW								
N <sub>A</sub> rpm	M <sub>2</sub> Nm	i	Fr <sub>2</sub> MAX[N]	f <sub>s</sub>	Type	Gear unit	Motor size	 Kg
28	20	100	1286	1.6	NMRV	025/030	5612	4.7
18.7	25	150	1472	1.1				
14	33	200	1620	0.9				
14	38	100	1620	0.8	NMRV	025/030	5624	5.2
9.3	49	150	1830	0.6				
7	62	200	1830	0.5				
5.6	66	250	1830	0.5				
4.7	75	300	1830	0.4				
3.5	107	400	1830	0.3				
2.8	115	500	1830	0.3				
2.3	135	600	1830	0.2				
1.9	151	750	1830	0.2				
1.6	178	900	1830	0.2				
1.2	212	1200	1830	0.1				
0.9	247	1500	1830	0.1				
0.78	304	1800	1830	0.1				
0.58	340	2400	1830	0.1				
0.47	405	3000	1830	0.1				
28	19	50	2475	2.0	NMRV	040	5624	5.6
23.3	21	60	2630	1.7				
17.5	26	80	2895	1.3				
14	29	100	3118	1.0				
30	19	30	2419	2.6	NMRV	040	63M1-6	6.5
22.5	24	40	2662	1.9				
18	27	50	2868	1.5				
15	31	60	3047	1.3				
11.3	37	80	3354	1.0				
9	41	100	3490	0.8				
12	47	75	3283	1.3	NMRV	040+PC063	63M1-6	15
10	51	90	3488	1.4				
7.5	62	120	3490	1.1				
6	72	150	3490	0.8				
5	79	180	3490	0.7				
9.3	45	300	3490	1.6	NMRV	025/040	5612	5.8
7	54	400	3490	1.2				
5.6	77	500	3490	0.8				

**技术参数****Technical Data****P<sub>1</sub> = 0.09 KW**

N <sub>A</sub> rpm	M <sub>2</sub> Nm	i	Fr <sub>2</sub> MAX[N]	f <sub>s</sub>	Type	Gear unit	Motor size	Kg
4.7	88	300	3490	0.8	NMRV	030/040	5624	6.8
15 11.3 9	32 37 42	60 80 100	4183 4604 4840	2.3 1.8 1.3	NMRV	050	63M1-6	7.7
6 5 3.8 3	73 81 94 106	150 180 240 300	4840 4840 4840 4840	1.6 1.3 0.9 0.7	NMRV	050+PC063	63M1-6	16.2
3.5 2.8 2.3 1.9 1.6	107 123 159 185 212	400 500 600 750 900	4840 4840 4840 4840 4840	1.2 1.0 0.9 0.8 0.7	NMRV	030/050	5624	8.0
3.8 3	99 109	240 300	6270 6270	1.7 1.4	NMRV	063+PC063	63M1-6	18.9
1.6 1.2 0.93	200 263 305	900 1200 1500	6270 6270 6270	1.0 0.9 0.7	NMRV	030/063	5624	10.7
0.9 0.78 0.58	360 404 496	1500 1800 2400	7380 7380 7380	1.1 1.0 0.7	NMRV	040/075	5624	14.6
0.5 0.35	609 548	3000 4000	8180 8180	0.9 0.8	NMRV	040/090	5624	18.6

**P<sub>1</sub> = 0.12 KW**

560 373.3 280 186.7 140 93.3 70	1.8 2.7 3.5 5.0 6.5 9.0 11	5 7.5 10 15 20 30 40	349 399 439 503 553 633 697	4.4 3.0 2.6 1.8 1.4 1.0 0.8	NMRV	025	5622	3.9
280 286.7 140	3.6 5.2 6.7	5 7.5 10	597 683 752	5.1 3.4 2.7	NMRV	030	63M1-4	5.1

**技术参数****Technical Data**

<b>P<sub>1</sub> = 0.12 KW</b>								
<b>N<sub>A</sub></b> rpm	<b>M<sub>2</sub></b> Nm	<b>i</b>	<b>Fr<sub>2MAX</sub>[N]</b>	<b>f<sub>s</sub></b>	<b>Type</b>	<b>Gear unit</b>	<b>Motor size</b>	 Kg
93.3	9.5	15	861	1.9	NMRV	030	63M1-4	5.1
70	12	20	948	1.5				
56	14	25	1021	1.5				
46.7	16	30	1085	1.3				
35	19	40	1194	0.9				
28	23	50	1286	0.8				
180	5.4	5	692	3.7	NMRV	030	63M2-6	6.0
120	7.9	7.5	792	2.5				
90	10	10	871	2.0				
60	14	15	997	1.4				
45	18	20	1098	1.1				
36	20	25	1183	1.1				
30	23	30	1257	0.9				
46.7	17	30	2087	2.6	NMRV	040	63M1-4	6.2
35	21	40	2298	1.9				
28	25	50	2475	1.5				
23.3	28	60	2630	1.3				
17.5	34	80	2895	1.0				
14	38	100	3118	0.8				
30	25	30	2419	1.9	NMRV	040	63M2-6	7.1
22.5	32	40	2662	1.4				
18	36	50	2868	1.2				
15	41	60	3047	0.9				
18.7	42	75	2833	1.2	NMRV	040+PC063	63M1-4	14.7
15.6	46	90	3011	1.2				
11.7	57	120	3314	0.9				
9.3	66	150	3490	0.7				
7.8	74	180	3490	0.6				
12	62	75	3283	1.0	NMRV	040+PC063	63M2-6	15.6
10	68	90	3488	1.1				
7.5	83	120	3490	0.8				
23.3	29	60	3610	2.3	NMRV	050	63M1-4	7.4
17.5	35	80	3973	1.9				
14	40	100	4280	1.4				
22.5	32	40	3654	2.6	NMRV	050	63M2-6	8.3
18	38	50	3936	2.0				
15	42	60	4183	1.7	NMRV	050	63M2-6	8.3
11.3	50	80	4604	1.4				
9	56	100	4840	1.0				



技术参数

Technical Data

P <sub>1</sub> = 0.12 kW								
N <sub>A</sub> rpm	M <sub>2</sub> Nm	i	Fr <sub>2</sub> MAX[N]	f <sub>s</sub>	Type	Gear unit	Motor size	 Kg
9.3	68	150	4840	1.3	NMRV	050+PC063	63M1-4	12.0
7.8	75	180	4840	1.1				
5.8	88	240	4840	0.8				
4.7	98	300	4840	0.7				
12	63	75	4506	1.7	NMRV	050+PC063	63M2-6	16.8
10	70	90	4788	2.1				
7.5	84	120	4840	1.5				
6	97	150	4840	1.2				
5	108	180	4840	1.0				
3.8	125	240	4840	0.7				
4.7	119	300	4840	1.2	NMRV	030/050	63M1-4	8.6
3.5	142	400	4840	0.9				
2.8	164	500	4840	0.7				
5.8	92	240	6270	1.5	NMRV	063+PC063	63M1-4	10.1
4.7	103	300	6270	1.2				
6	101	150	6270	2.1	NMRV	063+PC063	63M2-6	11.0
5	112	180	6270	1.8				
3.8	131	240	6270	1.3				
3	145	300	6270	1.0				
2.8	171	500	6270	1.3	NMRV	030/063	63M1-4	11.3
2.3	208	600	6270	1.1				
1.9	241	750	6270	0.9				
1.6	325	900	7380	1.2	NMRV	040/075	63M1-4	15.2
1.2	399	1200	7380	0.9				
0.8	547	1800	8180	0.9	NMRV	040/090	63M1-4	19.2
0.58	695	2400	8180	0.9				
0.5	884	3000	10320	1.2	NMRV	050/110	63M1-4	42.4
0.35	784	4000	10320	1.0				
0.28	928	5000	10320	0.8				
560	2.7	5	474	4.4	NMRV	030	63M1-2	5.2
373.3	4	7.5	542	3.2				
280	5.2	10	597	2.5				
186.7	7.5	15	683	1.7	NMRV	030	63M1-2	5.2
140	10	20	752	1.3				
112	11	25	810	1.4				
93.3	13	30	861	1.1				
70	16	40	948	0.9				

**技术参数****Technical Data**

<b>P<sub>1</sub> = 0.18 kW</b>								
<b>N<sub>A</sub></b> rpm	<b>M<sub>2</sub></b> Nm	<b>i</b>	<b>Fr<sub>2MAX</sub>[N]</b>	<b>f<sub>s</sub></b>	<b>Type</b>	<b>Gear unit</b>	<b>Motor size</b>	 Kg
280	5.3	5	597	3.4	NMRV	030	63M1-4	5.1
186.7	7.8	7.5	683	2.3				
140	10	10	752	1.8				
93.3	14	15	861	1.3				
70	18	20	948	1.0				
56	21	25	1021	1.0				
46.7	24	30	1085	0.8				
93.3	14	30	1657	2.4	NMRV	040	63M1-2	6.3
70	18	40	1824	1.8				
56	21	50	1964	1.4				
70	19	20	1824	2.0	NMRV	040	63M1-4	6.2
56	23	25	1964	1.7				
46.7	26	30	2087	1.7				
35	32	40	2298	1.3				
28	38	50	2475	1.0				
23.3	43	60	2630	0.8				
45	29	20	2113	1.5	NMRV	040	71M1-6	8.3
36	34	25	2276	1.3				
30	38	30	2419	1.3				
22.5	47	40	2662	1.0				
18.7	64	75	2833	0.8	NMRV	040+PC063	63M1-4	14.8
15.6	70	90	3011	0.8				
11.7	85	120	3314	0.6				
46.7	24	60	2865	2.1	NMRV	050	63M1-2	7.5
35	30	80	3153	1.5				
28	34	100	3397	1.2				
35	33	40	3153	2.3	NMRV	050	63M1-4	7.4
28	39	50	3397	1.9				
23.3	43	60	3610	1.6				
17.5	52	80	3973	1.2				
14	60	100	4280	0.9				
18	56	50	3936	1.4	NMRV	050	71M1-6	9.5
15	63	60	4183	1.1				
11.3	75	80	4604	0.9				



**技术参数****Technical Data**

<b>P<sub>1</sub> = 0.18 kW</b>								
<b>N<sub>A</sub></b> rpm	<b>M<sub>2</sub></b> Nm	<b>i</b>	<b>Fr<sub>2MAX</sub>[N]</b>	<b>f<sub>s</sub></b>	<b>Type</b>	<b>Gear unit</b>	<b>Motor size</b>	 Kg
18.7	64	75	3889	1.4	NMRV	050+PC063	63M1-4	15.9
15.6	71	90	4132	1.5				
11.7	87	120	4548	1.1				
9.3	101	150	4840	0.9				
7.8	113	180	4840	0.7				
5.8	133	240	4840	0.6				
12.0	95	75	4506	1.2	NMRV	050+PC071	71M1-6	20.0
10.0	105	90	4788	1.4				
7.5	126	120	4840	1.0				
15	66	60	5467	2.1	NMRV	063	71M1-6	12.2
11.3	79	80	6018	1.6				
9	90	100	6270	1.4				
9.3	103	150	6270	1.7	NMRV	063+PC063	63M1-4	18.6
7.8	117	180	6270	1.4				
5.8	139	240	6270	1.0				
4.7	155	300	6270	0.8				
12.0	97	75	5889	2.2	NMRV	063+PC071	71M1-6	22.7
10.0	107	90	6259	2.4				
7.5	131	120	6270	1.8				
6.0	152	150	6270	1.4				
5.0	168	180	6270	1.2				
3.8	197	240	6270	0.9				
3.0	218	300	6270	0.7				
3.5	222	400	6270	1.0	NMRV	030/063	63M1-4	11.3
2.8	257	500	6270	0.8				
5.0	179	180	7380	1.7	NMRV	075+PC071	71M1-6	25.5
3.8	211	240	7380	1.2				
3.0	235	300	7380	1.0				
2.3	362	600	7380	1.1	NMRV	040/075	63M1-4	15.2
1.9	435	750	7380	0.9				
1.6	487	900	7380	0.8				
1.2	629	1200	8180	1.0	NMRV	040/090	63M1-4	19.2
0.93	735	1500	8180	0.8				
0.8	861	1800	10320	1.5	NMRV	050/110	63M1-4	42.4
0.58	1113	2400	10320	1.1				



### 技术参数

### Technical Data

P <sub>1</sub> = 0.25 kW								
NA rpm	M <sub>2</sub> Nm	I	Fr <sub>2</sub> MAX[N]	f <sub>s</sub>	Type	Gear unit	Motor size	 Kg
560	3.8	5	474	3.2	NMRV	030	63M2-2	5.2
373.3	5.6	7.5	542	2.3				
280	7.2	10	597	1.8				
186.7	10	15	683	1.3				
140	13	20	752	0.9				
112	16	25	810	1.0				
93.3	18	30	861	0.8				
280	8	5	1149	4.5	NMRV	040	71M1-4	7.7
186.7	11	7.5	1315	3.6				
140	14	10	1447	2.8				
93.3	21	15	1657	1.9				
70	27	20	1824	1.5				
56	32	25	1964	1.2				
46.7	36	30	2087	1.3				
35	44	40	2298	0.9				
180	12	5	1331	3.5	NMRV	040	71M2-6	8.8
120	17	7.5	1524	2.6				
90	22	10	1677	2.0				
60	31	15	1920	1.4				
45	40	20	2113	1.1				
36	48	25	2276	0.9				
30	53	30	2419	0.9				
35	42	80	3153	1.1	NMRV	040	63M2-2	6.7
28	48	100	3397	0.8				
70	27	20	2503	2.7	NMRV	050	71M1-4	8.9
56	32	25	2696	2.2				
46.7	37	30	2865	2.3				
35	46	40	3153	1.7				
28	54	50	3397	1.4				
23.3	60	60	3610	1.1				
17.5	72	80	3973	0.9				
45	40	20	2900	1.9	NMRV	050	71M2-6	10.0
36	48	25	3124	1.5				
30	54	30	3320	1.7				
22.5	67	40	3654	1.2				
18	78	50	3936	1.0				
15	88	60	4183	0.8				
18.7	88	75	3889	1.0	NMRV	050+PC071	71M1-4	19.4
15.6	98	90	4132	1.1				
11.7	121	120	4548	0.8				

**技术参数****Technical Data**

<b>P<sub>1</sub> = 0.25 kW</b>								
<b>N<sub>A</sub></b> rpm	<b>M<sub>2</sub></b> Nm	<b>i</b>	<b>Fr<sub>2MAX</sub>[N]</b>	<b>f<sub>s</sub></b>	<b>Type</b>	<b>Gear unit</b>	<b>Motor size</b>	 Kg
28	56	50	4440	2.4	NMRV	063	71M1-4	11.6
23.3	63	60	4719	2.0				
17.5	78	80	5193	1.6				
14	87	100	5595	1.4				
18	81	50	5145	1.8	NMRV	063	71M2-6	12.7
15	92	60	5467	1.5				
11.3	110	80	6018	1.2				
9	125	100	6270	1.0				
18.7	91	75	5083	1.8	NMRV	063+PC071	71M1-4	22.1
15.6	100	90	5401	2.0				
11.7	125	120	5945	1.5				
9.3	143	150	6270	1.2				
7.8	163	180	6270	1.0				
5.8	192	240	6270	0.7				
4.7	215	300	6270	0.6				
12.0	135	75	5889	1.6	NMRV	063+PC071	71M2-6	23.2
10.0	148	90	6259	1.8				
7.5	181	120	6270	1.3				
6.0	211	150	6270	1.0				
7	159	400	6270	1.4	NMRV	030/063	63M2-2	11.8
5.6	185	500	6270	1.2				
17.5	82	80	6130	2.3	NMRV	075	71M1-4	14.4
14	94	100	6603	1.9				
11.3	117	80	7103	1.7	NMRV	075	71M2-6	15.5
9	133	100	7380	1.4				
9.3	151	150	7380	1.7	NMRV	075+PC071	71M1-4	24.9
7.8	172	180	7380	1.4				
5.8	201	240	7380	1.1				
4.7	230	300	7380	0.9				
12.0	139	75	6952	2.4	NMRV	075+PC071	71M2-6	26.0
10.0	155	90	7380	2.5				
7.5	191	120	7380	1.9				
6.0	219	150	7380	1.5				
5.0	248	180	7380	1.2				
3.5	336	400	7380	1.1	NMRV	040/075	71M1-4	16.7
2.8	384	500	7380	0.8				

**技术参数****Technical Data****P<sub>1</sub> = 0.25 kW**

N <sub>A</sub> rpm	M <sub>2</sub> Nm	i	Fr <sub>2</sub> MAX[N]	f <sub>s</sub>	Type	Gear unit	Motor size	Kg
5.0	263	180	8180	1.9	NMRV	090+PC071	71M2-6	30.0
3.8	318	240	8180	1.4				
3.0	358	300	8180	1.1				
2.3	512	600	8180	1.2	NMRV	040/090	71M1-4	20.7
1.9	598	750	8180	0.9				
1.6	667	900	8180	0.8				
1.2	943	1200	10320	1.3	NMRV	050/110	71M1-4	43.9
0.93	1064	1500	10320	1.2				
0.78	1195	1800	10320	1.1				
0.6	1624	2400	13500	1.0	NMRV	063/130	71M1-4	59.6
0.47	1935	3000	13500	0.8				
0.35	2046	4000	13500	0.6				
0.28	2430	5000	13500	0.5				
0.8	1199	1800	18000	1.8	NMRV	063/150	71M1-4	95.6
0.6	1446	2400	18000	1.8				
0.5	1713	3000	18000	1.4				
0.4	2026	4000	18000	0.9				
0.3	2251	5000	18000	0.7				

**P<sub>1</sub> = 0.37 kW**

560	5.6	5	474	2.1	NMRV	030	6332	6.1
373.3	8.2	7.5	542	1.6				
280	11	10	597	1.2				
186.7	15	15	683	0.8				
560	5.7	5	912	4.2	NMRV	040	71M1-2	7.9
373.3	8.4	7.5	1044	3.3				
280	11	10	1149	2.6				
186.7	16	15	1315	1.9				
140	21	20	1447	1.4				
112	20	25	1559	1.1				
280	11	5	1149	3.0	NMRV	040	71M2-4	8.5
186.7	16	7.5	1315	2.4				
140	21	10	1447	1.9				
93.3	31	15	1657	1.3				
70	39	20	1824	1.0				
56	47	25	1964	0.8				
46.7	53	30	2087	0.8				

**技术参数****Technical Data**

<b>P<sub>1</sub> = 0.37kW</b>								
<b>N<sub>A</sub></b> rpm	<b>M<sub>2</sub></b> Nm	<b>i</b>	<b>Fr<sub>2MAX</sub>[N]</b>	<b>f<sub>s</sub></b>	<b>Type</b>	<b>Gear unit</b>	<b>Motor size</b>	 Kg
112	25	25	2140	2.2	NMRV	050	71M1-2	9.1
93.3	29	30	2274	2.2				
70	37	40	2503	1.6				
56	44	50	2696	1.2				
46.7	50	60	2865	1.0				
35	62	80	3153	0.7				
140	22	10	1987	3.3	NMRV	050	71M2-4	9.7
93.3	31	15	2274	2.4				
70	40	20	2503	1.8				
56	48	25	2696	1.5				
46.7	55	30	2865	1.5				
35	68	40	3153	1.1				
28	80	50	3397	0.9				
23.3	89	60	3610	0.8				
180	17	5	1827	4.3	NMRV	050	80M1-6	11.7
120	25	7.5	2091	3.3				
90	33	10	2302	2.5				
60	47	15	2635	1.8				
45	60	20	2900	1.3				
36	72	25	3124	1.0				
30	80	30	3320	1.1				
35	71	40	4122	2.1	NMRV	063	71M2-4	12.4
28	83	50	4440	1.6				
23.3	94	60	4719	1.4				
17.5	115	80	5193	1.1				
14	129	100	5595	0.9				
45	60	20	3791	2.4	NMRV	063	80M1-6	14.4
36	74	25	4084	1.9				
30	82	30	4339	2.1				
22.5	102	40	4776	1.6				
18	120	50	5145	1.2				
15	137	60	5467	1.0				
18.7	134	75	5083	1.2	NMRV	063+PC071	71M2-4	22.9
15.6	148	90	5401	1.4				
11.7	185	120	5945	1.0				
9.3	212	150	6270	0.8				
9.3	181	300	6270	1.3	NMRV	030/063	71M1-2	13.0
7	236	400	6270	1.0				

**技术参数****Technical Data**

<b>P<sub>1</sub> = 0.37kW</b>								
<b>N<sub>A</sub></b> rpm	<b>M<sub>2</sub></b> Nm	<b>i</b>	<b>Fr<sub>2MAX</sub>[N]</b>	<b>f<sub>s</sub></b>	<b>Type</b>	<b>Gear unit</b>	<b>Motor size</b>	 Kg
23.3	98	60	5569	2.0	NMRV	075	71M2-4	15.2
17.5	121	80	6130	1.6				
14	139	100	6603	1.3				
18	126	50	6073	1.8	NMRV	075	80M1-6	14.4
15	144	60	6453	1.5				
11.3	173	80	7103	1.2				
9	196	100	7380	1.0				
18.7	138	75	6000	1.8	NMRV	075+PC071	71M2-4	25.7
15.6	154	90	6375	1.9				
11.7	191	120	7017	1.5				
9.3	223	150	7380	1.1				
7.8	254	180	7380	0.9				
12.0	206	75	6952	1.6	NMRV	075+PC080	80M1-6	30.5
10.0	230	90	7380	1.7				
7.5	283	120	7380	1.3				
6.0	324	150	7380	1.0				
4.7	405	300	7380	1.0	NMRV	040/075	71M2-4	17.5
3.5	498	400	7380	0.7				
11.3	185	80	7859	1.7	NMRV	090	80M1-6	21.2
9	212	100	8180	1.3				
7.8	268	180	8180	1.5	NMRV	090+PC071	71M2-4	29.7
5.8	321	240	8180	1.1				
4.7	371	300	8180	0.9				
6.0	347	150	8180	1.6	NMRV	090+PC080	80M1-6	34.5
5.0	389	180	8180	1.3				
3.8	471	240	8180	1.0				
4.7	402	300	8180	1.5	NMRV	040/090	71M2-4	21.5
3.5	523	400	8180	1.2				
2.8	611	500	8180	0.9				
2.3	757	600	8180	0.8				
3.8	509	240	10320	1.6	NMRV	110+PC080	80M1-6	56.5
3.0	577	300	10320	1.3				
1.9	950	750	10320	1.3	NMRV	050/110	71M2-4	44.7
1.6	1079	900	10320	1.2				
1.2	1396	1200	10320	0.8				



技术参数

Technical Data

<b>P<sub>1</sub> = 0.37kW</b>								
-------------------------------	--	--	--	--	--	--	--	--

N <sub>A</sub> rpm	M <sub>2</sub> Nm	i	Fr <sub>2</sub> MAX[N]	f <sub>s</sub>	Type	Gear unit	Motor size	Kg
0.9	1674	1500	13500	1.1	NMRV	063/130	71M2-4	60.4
0.78	1887	1800	13500	0.9				
0.8	1775	1800	18000	1.2	NMRV	063/150	71M2-4	96.4
0.6	2141	2400	18000	1.2				
0.5	2535	3000	18000	0.9				

<b>P<sub>1</sub> = 0.55kW</b>								
-------------------------------	--	--	--	--	--	--	--	--

560	8.4	5	912	2.8	NMRV	040	71M2-2	8.4
373.	13	7.5	1044	2.2				
280	17	10	1149	1.8				
186.7	24	15	1315	1.3				
140	31	20	1447	0.9				
112	37	25	1559	0.8				
280	17	5	1149	2.0	NMRV	040	7134	9.6
186.7	24	7.5	1315	1.6				
140	32	10	1447	1.3				
93.3	46	15	1657	0.9				
140	31	20	1987	1.7	NMRV	050	71M2-2	9.6
112	38	25	2140	1.4				
93.3	43	30	2274	1.5				
70	55	40	2503	1.1				
56	65	50	2696	0.8				
46.7	74	60	2865	0.7				
280	17	5	1577	3.7				
186.7	25	7.5	1805	2.9	NMRV	050	80M1-4	12.5
140	32	10	1987	2.2				
93.3	46	15	2274	1.6				
70	59	20	2503	1.2				
56	71	25	2696	1.0				
46.7	81	30	2865	1.0				
120	38	7.5	2091	2.2	NMRV	050	80M2-6	13.4
90	49	10	2302	1.7				
60	69	15	2635	1.2				
45	89	20	2900	0.9				
70	56	40	3272	1.9	NMRV	063	71M2-2	12.3
56	67	50	3524	1.5				
46.7	77	60	3745	1.2				
35	95	80	4122	0.9				
28	109	100	4440	0.7				

**技术参数****Technical Data**

<b>P<sub>1</sub> = 0.55 kW</b>								
<b>N<sub>A</sub></b> rpm	<b>M<sub>2</sub></b> Nm	<b>i</b>	<b>Fr<sub>2</sub>MAX[N]</b>	<b>f<sub>s</sub></b>	<b>Type</b>	<b>Gear unit</b>	<b>Motor size</b>	 Kg
70	61	20	3272	2.2	NMRV	063	80M1-4	15.2
56	73	25	3524	1.8				
46.7	83	30	3745	1.9				
35	105	40	4122	1.4				
28	124	50	4440	1.1				
23.3	140	60	4719	0.9				
60	71	15	3444	2.2	NMRV	063	80M2-6	16.1
45	90	20	3791	1.6				
36	109	25	4084	1.3				
30	123	30	4339	1.4				
22.5	152	40	4776	1.1				
18.7	200	75	5083	0.8	NMRV	063+PC071	7134	24.0
15.6	219	90	5401	0.9				
35	99	80	4865	1.3	NMRV	075	71M2-2	15.1
28	114	100	5241	1.0				
35	108	40	4865	2.0	NMRV	075	80M1-4	18.0
28	129	50	5241	1.6				
23.3	146	60	5569	1.4				
17.5	180	80	6130	1.1				
14	206	100	6603	0.9				
30	128	30	5122	2.0	NMRV	075	80M2-6	18.9
22.5	159	40	5637	1.5				
18	187	50	6073	1.2				
15	214	60	6453	1.0				
18.7	205	75	6000	1.2	NMRV	075+PC071	7134	26.8
15.6	230	90	6375	1.3				
11.7	284	120	7017	1.0				
18.7	205	75	6000	1.2	NMRV	075+PC080	80M1-4	31.3
15.6	230	90	6375	1.3				
11.7	284	120	7017	1.0				
9.3	332	150	7380	0.8				
12.0	306	75	6952	1.1	NMRV	075+PC080	80M2-6	32.2
10.0	341	90	7380	1.1				
17.5	189	80	6783	1.5	NMRV	090	80M1-4	22.0
14	221	100	7306	1.2				



**技术参数****Technical Data**

<b>P<sub>1</sub> = 0.55 kW</b>								
<b>N<sub>A</sub></b> rpm	<b>M<sub>2</sub></b> Nm	<b>i</b>	<b>Fr<sub>2MAX</sub>[N]</b>	<b>f<sub>s</sub></b>	<b>Type</b>	<b>Gear unit</b>	<b>Motor size</b>	 <b>Kg</b>
18	198	50	6719	2.0	NMRV	090	80M2-6	22.9
15	224	60	7140	1.6				
11.3	275	80	7859	1.1				
9	315	100	8180	0.9				
15.6	240	90	7054	2.3	NMRV	090+PC080	80M1-4	35.3
11.7	297	120	7764	1.6				
9.3	355	150	8180	1.3				
7.8	398	180	8180	1.0				
10.0	357	90	8174	2.0	NMRV	090+PC080	80M2-6	36.2
7.5	441	120	8180	1.4				
6.0	516	150	8180	1.1				
5.0	578	180	8180	0.9				
9.3	306	300	8180	2.0	NMRV	040/090	71M2-2	21.4
7	403	400	8180	1.5				
5.6	470	500	8180	1.2				
17.5	201	80	8571	2.6	NMRV	110	80M1-4	44.0
14	236	100	9232	2.0				
11.3	294	80	9931	1.9	NMRV	110	80M2-6	44.9
9	338	100	10320	1.5				
7.8	425	180	10320	1.8	NMRV	110+PC080	80M1-4	57.3
5.8	513	240	10320	1.3				
4.7	597	300	10320	1.0				
7.5	462	120	10320	2.6	NMRV	110+PC080	80M2-6	58.2
6.0	552	150	10320	2.0				
5.0	620	180	10320	1.6				
3.8	756	240	10320	1.1				
4.7	639	300	10320	2.0	NMRV	050/110	80M1-4	47.5
3.5	826	400	10320	1.4				
2.8	984	500	10320	1.1				
2.3	1181	600	10320	1.0				
1.9	1411	750	10320	0.9				
3.8	756	240	13500	1.6	NMRV	130+PC080	80M2-6	71.2
3.0	858	300	13500	1.3				
2.8	996	500	13500	1.6	NMRV	063/130	80M1-4	63.2
1.9	1471	750	13500	1.2				
1.2	2132	1200	13500	0.8				



### 技术参数

### Technical Data

<b>P<sub>1</sub> = 0.55 kW</b>								
--------------------------------	--	--	--	--	--	--	--	--

N <sub>A</sub> rpm	M <sub>2</sub> Nm	i	Fr <sub>2</sub> MAX[N]	f <sub>s</sub>	Type	Gear unit	Motor size	Kg
0.8	2638	1800	18000	0.8	NMRV	063/150	80M1-4	99.2
0.6	3182	2400	18000	0.8				

<b>P<sub>1</sub> = 0.75 kW</b>								
--------------------------------	--	--	--	--	--	--	--	--

560	12	5	1251	3.9	NMRV	050	80M1-2	12.6
373.3	17	7.5	1433	3.0				
280	23	10	1577	2.4				
186.7	33	15	1805	1.7				
140	42	20	1987	1.3				
112	51	25	2140	1.0				
93.3	58	30	2274	1.1				
280	23	5	1577	2.7	NMRV	050	80M2-4	13.5
186.7	34	7.5	1805	2.1				
140	44	10	1987	1.6				
93.3	63	15	2274	1.2				
70	81	20	2503	0.9				
140	43	20	2597	2.3	NMRV	063	80M1-2	15.3
112	52	25	2797	1.8				
93.3	60	30	2973	2.0				
70	77	40	3272	1.4				
56	91	50	3524	1.1				
46.7	104	60	3745	0.9				
93.3	64	15	2973	2.2	NMRV	063	80M2-4	16.2
70	83	20	3272	1.6				
56	100	25	3524	1.3				
46.7	114	30	3745	1.4				
35	143	40	4122	1.0				
120	52	7.5	2734	2.9	NMRV	063	90S-6	17.9
90	68	10	3009	2.3				
60	97	15	3444	1.6				
45	123	20	3791	1.2				
36	149	25	4084	0.9				
30	167	30	4339	1.0				
46.7	109	60	4421	1.3	NMRV	075	80M1-2	18.1
28	156	100	5241	0.8				
56	102	25	4160	2.0	NMRV	075	80M2-4	19.0
46.7	117	30	4421	2.0				
35	147	40	4865	1.5				
28	177	50	5241	1.2				
23.3	200	60	5569	1.0				



技术参数

Technical Data

P <sub>1</sub> = 0.75 kW								
NA rpm	M <sub>2</sub> Nm	i	Fr <sub>2</sub> MAX[N]	f <sub>s</sub>	Type	Gear unit	Motor size	 Kg
60.0	98	15	4065	2.4	NMRV	075	90S-6	20.7
45.0	126	20	4474	1.9				
36.0	153	25	4820	1.4				
30.0	174	30	5122	1.5				
22.5	216	40	5637	1.1				
18.7	280	75	6000	0.9	NMRV	075+PC080	80M2-4	32.3
15.6	313	90	6375	1.0				
35	141	80	5383	1.6	NMRV	090	80M1-2	22.1
28	166	100	5799	1.2				
28	184	50	5799	1.8	NMRV	090	80M2-4	23.0
23.3	212	60	6163	1.5				
17.5	258	80	6783	1.1				
14	302	100	7306	0.9				
30	179	30	5667	2.6	NMRV	090	90S-6	24.7
22.5	226	40	6238	1.8				
18	271	50	6719	1.4				
15	306	60	7140	1.1				
15.6	327	90	7054	1.7	NMRV	090+PC080	80M2-4	36.3
11.7	405	120	7764	1.2				
9.3	483	150	8180	0.9				
7.8	543	180	8180	0.7				
7	549	400	8180	1.1	NMRV	040/090	80M1-2	24.4
5.6	642	500	8180	0.9				
17.5	274	80	8571	1.9	NMRV	110	80M2-4	45.0
14	322	100	9232	1.5				
15	325	60	9023	2.1	NMRV	110	90S-6	46.7
11.3	401	80	9931	1.4				
9	462	100	10320	1.1				
12.4	393	73	9641	3.2	NMRV	110+PC090	90S-6	60.0
9.3	508	96.8	10320	2.3				
7.4	607	121	10320	1.8				
6.2	682	145.2	10320	1.5				
4.6	832	193.6	10320	1.0				
9.3	446	300	10320	2.8	NMRV	050/110	80M1-2	47.6
7	563	400	10320	2.1				
5.6	687	500	10320	1.6				



技术参数

Technical Data

<b>P<sub>1</sub> = 0.75 kW</b>								
--------------------------------	--	--	--	--	--	--	--	--

N <sub>A</sub> rpm	M <sub>2</sub> Nm	i	Fr <sub>2</sub> MAX[N]	f <sub>s</sub>	Type	Gear unit	Motor size	Kg
4.7	871	300	10320	1.5	NMRV	050/110	80M2-4	48.5
3.5	1126	400	10320	1.1				
11.3	407	80	12989	2.1	NMRV	130	90S-6	59.7
9	470	100	13500	1.7				
5.8	712	240	13500	1.4	NMRV	130+PC080	80M2-4	71.3
4.7	813	300	13500	1.1				
12.4	399	73	12575	4.4	NMRV	130+PC090	90S-6	73.0
9.3	508	96.8	13500	3.2				
7.4	607	121	13500	2.6				
6.2	682	145.2	13500	2.1				
4.6	832	193.6	13500	1.5				
3.7	944	242	13500	1.2				
2.8	1291	500	13500	1.1	NMRV	063/130	80M2-4	64.2
2.3	1529	600	13500	1.0				
1.9	2005	750	13500	0.9				
1.6	2283	900	13500	0.8				
2.8	1291	500	18000	1.8	NMRV	063/150	80M2-4	100.2
2.3	1529	600	18000	1.7				
1.9	1783	750	18000	1.3				
1.6	2215	900	18000	0.9				
1.2	2680	1200	18000	1.0				

<b>P<sub>1</sub> = 1.1 kW</b>								
-------------------------------	--	--	--	--	--	--	--	--

560	17	5	1251	2.6	NMRV	050	80M2-2	13.7
373.3	25	7.5	1433	2.1				
280	33	10	1577	1.6				
186.7	48	15	1805	1.2				
140	62	20	1987	0.9				
186.7	48	15	2359	2.1	NMRV	063	80M2-2	16.4
140	63	20	2597	1.6				
112	77	25	2797	1.2				
93.3	88	30	2973	1.4				
70	113	40	3272	1.0				
120	76	7.5	2734	2.0	NMRV	063	90L-6	21.3
90	99	10	3009	1.5				
60	142	15	3444	1.1				
45	180	20	3791	0.8				



技术参数

Technical Data

P <sub>1</sub> = 1.1 kW								
Na rpm	M <sub>2</sub> Nm	i	Fr <sub>2</sub> MAX[N]	f <sub>s</sub>	Type	Gear unit	Motor size	 Kg
186.7	50	7.5	2359	2.6	NMRV	063	90S-4	18.3
140	65	10	2597	2.0				
93.3	93	15	2973	1.5				
70	122	20	3272	1.1				
56	146	25	3524	0.9				
46.7	167	30	3745	1.0				
112	78	25	3302	1.9	NMRV	075	80M2-2	19.2
93.3	90	30	3509	1.9				
70	116	40	3862	1.4				
56	139	50	4160	1.1				
46.7	160	60	4421	0.9				
90	100	10	3551	2.3	NMRV	075	90L-6	24.1
60	144	15	1065	1.6				
45	184	20	4474	1.3				
36	225	25	4820	1.0				
30	256	30	5122	1.0				
93.3	96	15	3509	2.1	NMRV	075	90S-4	21.1
70	123	20	3862	1.7				
56	150	25	4160	1.3				
46.7	171	30	4421	1.3				
35	216	40	4865	1.0				
35	207	80	5383	1.1	NMRV	090	80M2-2	23.2
28	244	100	5799	0.8				
36	231	25	5333	1.6	NMRV	090	90L-6	28.1
30	263	30	5667	1.8				
22.5	331	40	6238	1.2				
18	397	50	6719	1.0				
15	448	60	7140	0.8				
35	225	40	5383	1.6	NMRV	090	90S-4	25.1
28	270	50	5799	1.3				
23.3	311	60	6163	1.0				
22.5	345	40	7882	2.3	NMRV	110	90L-6	50.1
18	414	50	8491	1.8				
15	476	60	9023	1.4				
11.3	588	80	9931	1.0				
28	281	50	7328	2.3	NMRV	110	90S-4	47.1
23.3	324	60	7787	1.9				
17.5	402	80	8571	1.3				
14	473	100	9232	1.0				

**技术参数****Technical Data**

<b>P<sub>1</sub> = 1.1 kW</b>								
<b>N<sub>A</sub></b> rpm	<b>M<sub>2</sub></b> Nm	<b>i</b>	<b>Fr<sub>2MAX</sub>[N]</b>	<b>f<sub>s</sub></b>	<b>Type</b>	<b>Gear unit</b>	<b>Motor size</b>	 Kg
12.4	576	73	9614	2.2	NMRV	110+PC090	90L-6	63.4
9.3	746	96.8	10320	1.6				
7.4	890	121	10320	1.2				
6.2	1000	145.2	10320	1.0				
19.3	392	73	8298	2.5	NMRV	110+PC090	90S-4	60.4
14.5	508	96.8	9133	1.8				
11.6	599	121	9838	1.5				
9.6	686	145.2	10320	1.1				
7.2	828	193.6	10320	0.8				
9.3	654	300	10320	1.9	NMRV	050/110	80M2-2	48.7
7	845	400	10320	1.4				
5.6	1007	500	10320	1.1				
11.3	598	80	12989	1.4	NMRV	130	90L-6	63.1
9	689	100	13500	1.1				
17.5	408	80	11210	2.1	NMRV	130	90S-4	60.1
14	480	100	12076	1.5				
12.4	585	73	12575	3.0	NMRV	130+PC090	90L-6	76.4
9.3	746	96.8	13500	2.2				
7.4	890	121	13500	1.7				
6.2	1000	145.2	13500	1.4				
4.6	1220	193.6	13500	1.0				
19.3	398	73	10853	3.5	NMRV	130+PC090	90S-4	73.4
14.5	508	96.8	11945	2.6				
11.6	608	121	12868	2.0				
9.6	686	145.2	13500	1.6				
7.2	843	193.6	13500	1.2				
5.8	962	242	13500	0.9				
4.7	1312	300	13500	1.3	NMRV	063/130	90S-4	66.3
3.5	1671	400	13500	1.0				
2.8	1991	500	13500	0.8				
9.3	753	150	18000	3.1	NMRV	063/150	90S-4	102.3
7	966	200	18000	2.4				
5.6	1175	250	18000	1.7				
4.7	1364	300	18000	1.7				



技术参数

Technical Data

<b>P<sub>1</sub> = 1.1 kW</b>								
-------------------------------	--	--	--	--	--	--	--	--

N <sub>A</sub> rpm	M <sub>2</sub> Nm	i	Fr <sub>2</sub> MAX[N]	f <sub>s</sub>	Type	Gear unit	Motor size	Kg
3.5	1619	400	18000	1.6	NMRV	063/150	90S-4	102.3
2.8	1893	500	18000	1.2				
2.3	2242	600	18000	1.2				
1.9	2616	750	18000	0.9				

<b>P<sub>1</sub> = 1.5 kW</b>								
-------------------------------	--	--	--	--	--	--	--	--

186.7	68	7.5	2359	1.9	NMRV	063	90L-4	20.8
140	89	10	2597	1.5				
93.3	127	15	2973	1.1				
70	166	20	3272	0.8				
373.3	35	7.5	1873	2.7	NMRV	063	90S-2	18.2
280	46	10	2061	2.1				
186.7	66	15	2359	1.6				
140	86	20	2597	1.2				
112	102	25	2797	0.9				
93.3	120	30	2973	1.0				
120	105	7.5	3227	2.0	NMRV	075	100L-6	28.1
90	137	10	3551	1.7				
60	196	15	4065	1.2				
140	90	10	3065	2.2	NMRV	075	90L-4	23.6
93.3	130	15	3509	1.5				
70	168	20	3862	1.3				
56	205	25	4160	1.0				
46.7	233	30	4421	1.0				
280	46	10	2433	3.1	NMRV	075	90S-2	21.0
186.7	67	15	2785	2.2				
140	87	20	3065	1.8				
112	106	25	3302	1.4				
93.3	123	30	3509	1.4				
70	158	40	3862	1.0				
56	194	50	4603	1.4	NMRV	090	90S-2	25.0
46.7	227	60	4891	1.1				
90	138	10	3929	2.7	NMRV	090	100L-6	32.1
60	201	15	4498	2.1				
45	258	20	4951	1.5				
36	314	25	5333	1.2				
30	358	30	5667	1.3				

**技术参数****Technical Data**

P <sub>1</sub> = 1.5 kW								
NA rpm	M <sub>2</sub> Nm	i	Fr <sub>2</sub> MAX[N]	f <sub>s</sub>	Type	Gear unit	Motor size	 Kg
70	172	20	4273	2.1	NMRV	090	90L-4	27.6
56	210	25	4603	1.6				
46.7	239	30	4891	1.7				
35	307	40	5383	1.2				
28	368	50	5799	0.9				
23.3	424	60	6163	0.8				
45	264	20	6256	2.7	NMRV	110	100L-6	54.1
36	322	25	6739	2.4				
30	363	30	7161	2.3				
22.5	471	40	7882	1.7				
18	565	50	8491	1.3				
15	649	60	9023	1.1				
35	319	40	6803	2.2	NMRV	110	90L-4	49.6
28	384	50	7328	1.7				
23.3	442	60	7787	1.4				
17.5	548	80	8571	0.9				
46.7	236	60	6181	2.0	NMRV	110	90S-2	47.0
35	299	80	6803	1.3				
28	353	100	7328	1.0				
19.3	535	73	8298	1.9	NMRV	110+PC090	90L-4	49.6
14.5	693	96.8	9133	1.3				
11.6	817	121	9838	1.1				
9.6	936	145.2	10320	0.8				
9.3	891	300	10320	1.4	NMRV	050/110	90S-2	50.5
7	1153	400	10320	1.0				
5.6	1373	500	10320	0.8				
22.5	478	40	10309	2.3	NMRV	130	100L-6	67.1
18	573	50	11105	1.8				
15	659	60	11801	1.4				
11.3	815	80	12989	1.1				
17.5	557	80	11210	1.5	NMRV	130	90L-4	62.6
14	655	100	12076	1.1				
19.3	542	73	10853	2.6	NMRV	130+PC090	90L-4	75.9
14.5	693	96.8	11945	1.9				
11.6	830	121	12868	1.5				
9.6	936	145.2	13500	1.1				
7.2	1149	194	13500	0.8				
9.3	915	300	13500	1.9	NMRV	063/130	90S-2	66.2
7	1166	400	13500	1.4				
5.6	1389	500	13500	1.1				





技术参数

Technical Data

P <sub>1</sub> = 1.5 kW									
N <sub>A</sub> rpm	M <sub>2</sub> Nm	i	Fr <sub>2</sub> MAX[N]	f <sub>s</sub>	Type	Gear unit	Motor size	Kg	
4.7	1789	300	13500	1.0	NMRV	063/130	90L-4	68.8	
3.5	2279	400	13500	0.7					
9.3	1026	150	18000	2.3	NMRV	063/150	90L-4	104.8	
7	1317	200	18000	1.8					
5.6	1602	250	18000	1.3					
4.7	1860	300	18000	1.3					
3.5	2208	400	18000	1.2					
2.5	2582	500	18000	0.9					
2.3	3057	600	18000	0.9					
P <sub>1</sub> = 2.2 kW									
373.3	51	7.5	1873	1.8	NMRV	063	90L1-2	21.2	
280	67	10	2061	1.5					
186.7	97	15	2359	1.1					
186.7	100	7.5	2785	1.8	NMRV	075	100L1-4	30.0	
140	132	10	3065	1.5					
93.3	191	15	3509	1.0					
373.3	51	7.5	2210	2.5	NMRV	075	90L1-2	24	
280	68	10	2433	2.1					
186.7	98	15	2785	1.5					
140	128	20	3065	1.3					
112	156	25	3302	1.0					
93.3	180	30	3509	0.9					
186.7	101	7.5	3081	2.9	NMRV	090	100L1-4	34.0	
140	134	10	3391	2.3					
93.3	194	15	3882	1.9					
70	252	20	4273	1.4					
56	308	25	4603	1.1					
46.7	351	30	4891	1.2					
120	156	7.5	3570	2.2	NMRV	090	112M-6	38.4	
90	203	10	3929	1.8					
60	294	15	4498	1.4					
45	378	20	4951	1.0					
140	131	20	3391	2.0	NMRV	090	90L1-2	28.0	
112	159	25	3653	1.6					
93.3	185	30	3882	1.7					
70	237	40	4273	1.2					
56	285	50	4603	0.9					

**技术参数****Technical Data**

P <sub>1</sub> = 2.2 kW								
NA rpm	M <sub>2</sub> Nm	i	Fr <sub>2</sub> MAX[N]	f <sub>s</sub>	Type	Gear unit	Motor size	 Kg
70	255	20	5399	2.5	NMRV	110	100L1-4	56.0
56	315	25	5816	2.2				
46.7	356	30	6181	2.0				
35	468	40	6803	1.5				
28	563	50	7328	1.2				
23.3	648	60	7787	1.0				
90	205	10	4965	3.5	NMRV	110	112M-6	60.4
60	298	15	5684	2.6				
45	388	20	6256	1.9				
36	473	25	6739	1.6				
30	532	30	7161	1.6				
112	163	25	4616	3.1	NMRV	110	90L1-2	47.0
93.3	187	30	4905	3.0				
70	246	40	5399	2.1				
56	296	50	5816	1.7				
46.7	347	60	6181	1.4				
38.6	398	73	6586	2.1	NMRV	110+PC090	90L1-2	63.3
28.9	516	96.8	7249	1.5				
23.1	617	121	7809	1.2				
35	468	40	8897	2.2	NMRV	130	100L1-4	69
28	563	50	9584	1.7				
23.3	648	60	10185	1.1				
17.5	816	80	11210	1.0				
36	479	25	8814	2.2	NMRV	130	112M-6	73.4
30	546	30	9366	2.1				
22.5	700	40	10309	1.6				
18	840	50	11105	1.2				
15	966	60	11801	1.0				
35	438	80	8897	1.3	NMRV	130	90L1-2	63.0
28	525	100	9584	1.0				
38.6	409	73	8614	2.9	NMRV	130+PC090	90L1-2	76.3
28.9	545	96.8	9481	2.0				
23.1	654	121	10213	1.6				
19.3	752	145.2	10853	1.3				
28	570	50	13103	2.5	NMRV	150	100L1-4	105
23.3	657	60	13924	1.9				
17.5	816	80	15325	1.4				
14	960	100	16508	1.0				

**技术参数****Technical Data**

<b>P<sub>1</sub> = 3.0 kW</b>																																																																																																																																																																																																																													
<b>N<sub>A</sub></b> rpm	<b>M<sub>2</sub></b> Nm	<b>i</b>	<b>Fr<sub>2MAX</sub>[N]</b>	<b>f<sub>s</sub></b>	<b>Type</b>	<b>Gear unit</b>	<b>Motor size</b>	 Kg																																																																																																																																																																																																																					
373.3	70	7.5	2210	1.98	NMRV	075	100L-2	31.3																																																																																																																																																																																																																					
280	92	10	2433	1.6					186.7	137	7.5	2785	1.4	NMRV	075	100L2-4	33.7	140	180	10	3065	1.1	93.3	261	15	3509	0.8	373.3	71	7.5	2446	3.0	NMRV	090	100L-2	35.3	280	92	10	2692	2.6	186.7	138	7.5	3081	2.1	NMRV	090	100L2-4	37.7	140	182	10	3391	1.7	93.3	264	15	3882	1.4	70	344	20	4273	1.0	56	420	25	4603	0.8	46.7	479	30	4891	0.9	93.3	264	15	4905	2.5	NMRV	110	100L2-4	56.0	70	348	20	5399	1.9	56	430	25	5816	1.6	46.7	485	30	6181	1.5	35	638	40	6803	1.1	28	767	50	7328	0.9	120	212	7.5	4511	3.1	NMRV	110	132S-6	71.1	90	280	10	4965	2.5	60	406	15	5684	1.9	45	528	20	6256	1.4	56	430	25	7607	2.2	NMRV	130	100L2-4	72.7	46.7	491	30	8084	2.1	35	638	40	8897	1.6	28	767	50	9584	1.3	23.3	884	60	10185	1.0	17.5	1113	80	11210	0.8	90	280	10	6494	3.4	NMRV	130	132S-6	84.1	60	406	15	7434	2.6	45	535	20	8182	1.9	36	653	25	8814	1.6	30	745	30	9366	1.6	22.5	955	40	10309	1.2	28	778	50	13103	1.8	NMRV	150	100L2-4	108.7	23.3	896	60	13924	1.4	17.5	1113	80	15325	1.0	14
186.7	137	7.5	2785	1.4	NMRV	075	100L2-4	33.7																																																																																																																																																																																																																					
140	180	10	3065	1.1																																																																																																																																																																																																																									
93.3	261	15	3509	0.8																																																																																																																																																																																																																									
373.3	71	7.5	2446	3.0	NMRV	090	100L-2	35.3																																																																																																																																																																																																																					
280	92	10	2692	2.6																																																																																																																																																																																																																									
186.7	138	7.5	3081	2.1	NMRV	090	100L2-4	37.7																																																																																																																																																																																																																					
140	182	10	3391	1.7																																																																																																																																																																																																																									
93.3	264	15	3882	1.4																																																																																																																																																																																																																									
70	344	20	4273	1.0																																																																																																																																																																																																																									
56	420	25	4603	0.8																																																																																																																																																																																																																									
46.7	479	30	4891	0.9																																																																																																																																																																																																																									
93.3	264	15	4905	2.5	NMRV	110	100L2-4	56.0																																																																																																																																																																																																																					
70	348	20	5399	1.9																																																																																																																																																																																																																									
56	430	25	5816	1.6																																																																																																																																																																																																																									
46.7	485	30	6181	1.5																																																																																																																																																																																																																									
35	638	40	6803	1.1																																																																																																																																																																																																																									
28	767	50	7328	0.9																																																																																																																																																																																																																									
120	212	7.5	4511	3.1	NMRV	110	132S-6	71.1																																																																																																																																																																																																																					
90	280	10	4965	2.5																																																																																																																																																																																																																									
60	406	15	5684	1.9																																																																																																																																																																																																																									
45	528	20	6256	1.4																																																																																																																																																																																																																									
56	430	25	7607	2.2	NMRV	130	100L2-4	72.7																																																																																																																																																																																																																					
46.7	491	30	8084	2.1																																																																																																																																																																																																																									
35	638	40	8897	1.6																																																																																																																																																																																																																									
28	767	50	9584	1.3																																																																																																																																																																																																																									
23.3	884	60	10185	1.0																																																																																																																																																																																																																									
17.5	1113	80	11210	0.8																																																																																																																																																																																																																									
90	280	10	6494	3.4	NMRV	130	132S-6	84.1																																																																																																																																																																																																																					
60	406	15	7434	2.6																																																																																																																																																																																																																									
45	535	20	8182	1.9																																																																																																																																																																																																																									
36	653	25	8814	1.6																																																																																																																																																																																																																									
30	745	30	9366	1.6																																																																																																																																																																																																																									
22.5	955	40	10309	1.2																																																																																																																																																																																																																									
28	778	50	13103	1.8	NMRV	150	100L2-4	108.7																																																																																																																																																																																																																					
23.3	896	60	13924	1.4																																																																																																																																																																																																																									
17.5	1113	80	15325	1.0																																																																																																																																																																																																																									
14	1310	100	16508	0.8																																																																																																																																																																																																																									



技术参数

Technical Data

P <sub>1</sub> = 4 kW								
N <sub>A</sub> rpm	M <sub>2</sub> Nm	i	Fr <sub>2</sub> MAX[N]	f <sub>s</sub>	Type	Gear unit	Motor size	 Kg
373.3 280	93 123	7.5 10	2210 2433	1.4 1.2	NMRV	075	112M-2	35.7
186.7 140	182 240	7.5 10	2785 3065	1.0 0.8				
373.3 280	94 123	7.5 10	2446 2692	2.2 1.9	NMRV	090	112M-2	39.7
186.7 140 93.3 70	184 243 352 458	7.5 10 15 20	3081 3391 3882 4273	1.6 1.3 1.0 0.8				
140 93.3 70 56 46.7	243 352 464 573 647	10 15 20 25 30	4285 4905 5399 5816 6181	2.5 1.9 1.4 1.2 1.1	NMRV	110	112M-4	65.5
120 90 60	283 374 541	7.5 10 15	4511 4965 5684	2.3 1.9 1.4				
56 46.7 35 28 23.3	573 655 851 1023 1179	25 30 40 50 60	7607 8084 8897 9584 10185	1.6 1.6 1.2 1.0 0.8				
120 90 60 45 36	287 374 541 713 870	7.5 10 15 20 25	5901 6494 7434 8182 8814	3.1 2.6 2.0 1.5 1.2				
28 23.3 17.5	1037 1195 1484	50 60 80	13103 13924 15325	1.4 1.1 0.8				
P <sub>1</sub> = 5.5 kW								
186.7 140 93.3 70	253 334 484 638	7.5 10 15 20	3893 4285 4905 5399	2.2 1.8 1.4 1.0	NMRV	110	132S-4	75.4
140 93.3 70	334 490 645	10 15 20	5605 6416 7062	2.5 1.9 1.4				

**技术参数****Technical Data****P<sub>1</sub> = 5.5 kW**

<b>N<sub>A</sub></b> rpm	<b>M<sub>2</sub></b> Nm	<b>i</b>	<b>Fr<sub>2</sub>MAX[N]</b>	<b>f<sub>s</sub></b>	<b>Type</b>	<b>Gear unit</b>	<b>Motor size</b>	 Kg
56	788	25	7607	1.2	NMRV	130	132S-4	88.4
46.7	900	30	8084	1.2				
35	1171	40	8897	0.9				
70	645	20	9654	2.0	NMRV	150	132S-4	124.4
56	788	25	10400	1.5				
46.7	934	30	11051	1.3				
35	1171	40	12163	1.3				
38	1426	50	13103	1.0				
23.3	1634	60	13924	0.8				

**P<sub>1</sub> = 7.5 kW**

186.7	345	7.5	3893	1.6	NMRV	110	132M-4	84.6
140	455	10	4285	1.3				
93.3	660	15	4905	1.0				
186.7	349	7.5	5092	2.1	NMRV	130	132M-4	97.6
140	455	10	5605	1.8				
93.3	668	15	6416	1.4				
70	880	20	7062	1.0				
56	1074	25	7607	0.9				
46.7	1228	30	8084	0.8				
35	1596	40	8897	0.7				
70	880	20	9654	1.5	NMRV	150	132M-4	133.6
56	1074	25	10400	1.1				
46.7	1274	30	11051	0.9				
35	1596	40	12163	1.0				

**P<sub>1</sub> = 11 kW**

186.7	512	7.5	6962	2.3	NMRV	150	160M-4	162
140	675	10	7663	1.8				
93.3	990	15	8771	1.3				
70	1291	20	9654	1.0				
56	1576	25	10400	0.8				

**P<sub>1</sub> = 15 kW**

186.7	698	7.5	6962	1.7	NMRV	150	160L-4	182
140	921	10	7663	1.3				
93.3	1351	15	8771	0.9				
70	1760	20	9654	0.7				



安装尺寸

Mounting Dimensions

NMRV025..

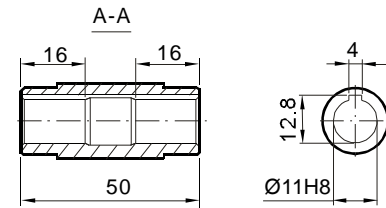
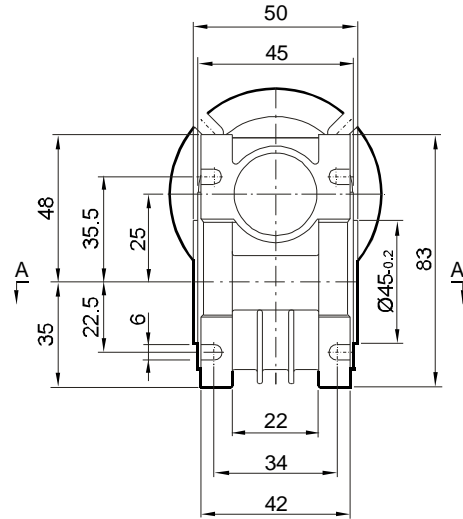
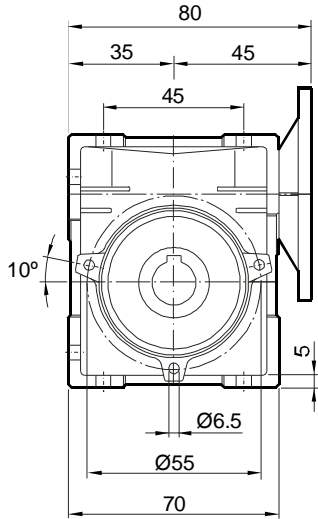

NMRV025..FA

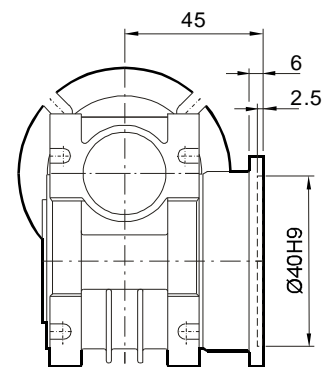
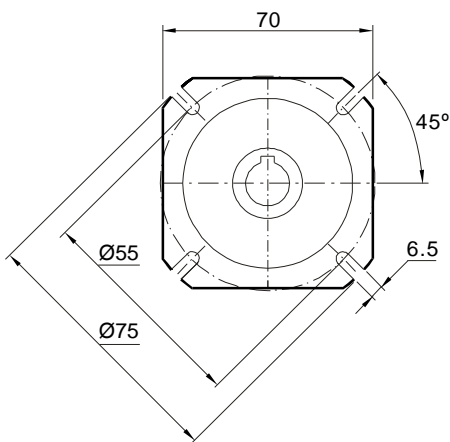

注意:

- 1 输入法兰尺寸详见76页;
- 2 减速器重量约0.7KG;
- 3 铝合金箱体。

ATTENTION

- 1 input flange dimensions shown on page 76;
- 2 worm gear reducer approximable weight 0.7 kg;
- 3 aluminium housing.



安装尺寸

Mounting Dimensions

NMRV030..

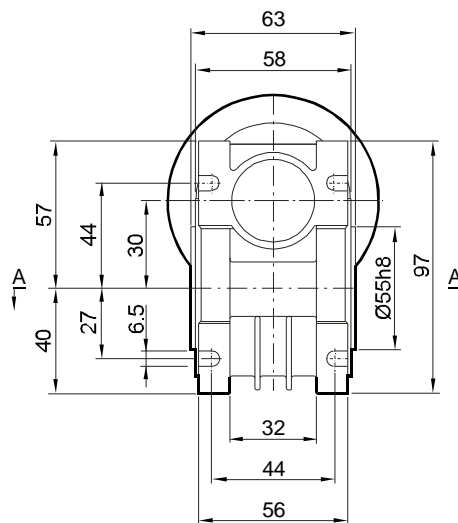
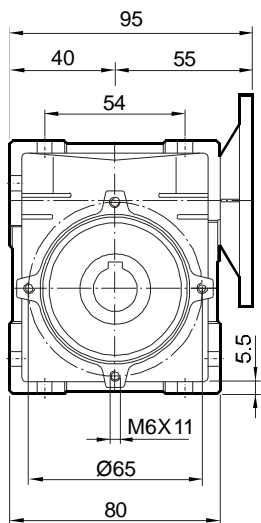

NMRV030..VS

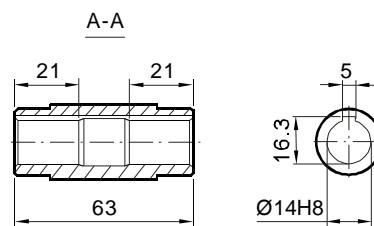
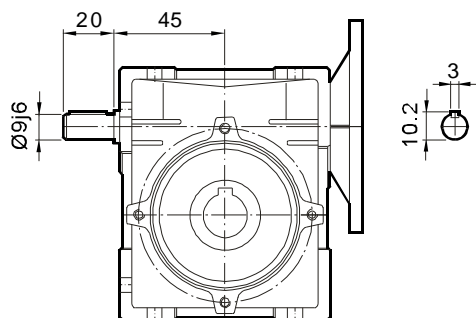

NMRV030..FA

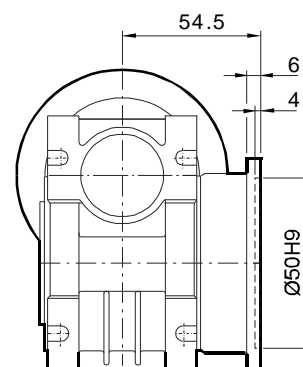
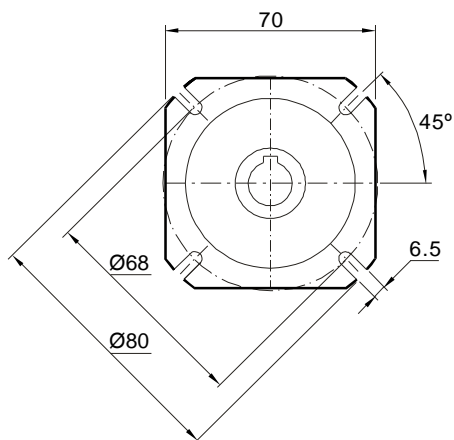

注意:

- 1 输入法兰尺寸详见76页;
- 2 减速器重量约1.2KG;
- 3 铝合金箱体。

ATTENTION

- 1 input flange dimensions shown on page 76;
- 2 worm gear reducer approximable weight 1.2 kg;
- 3 aluminium housing.



## 安装尺寸

## Mounting Dimensions

### NMRV040..

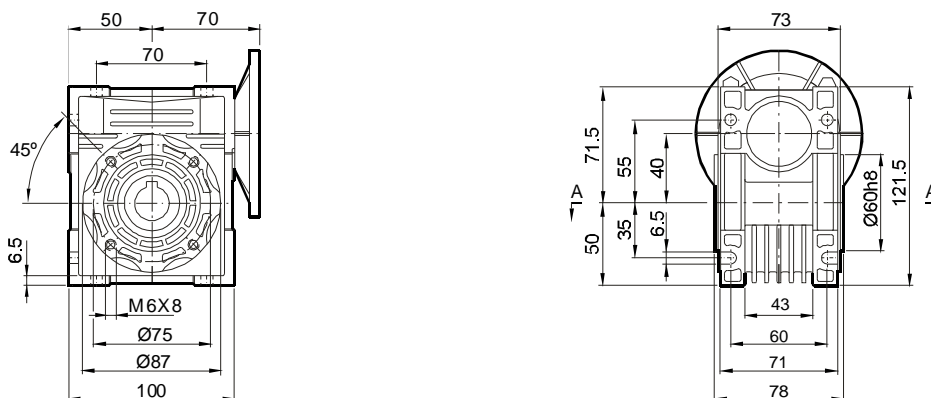

### NMRV040..VS

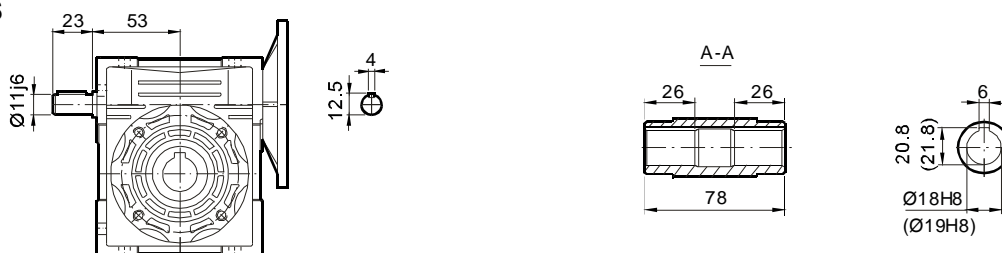

### NMRV040..FA

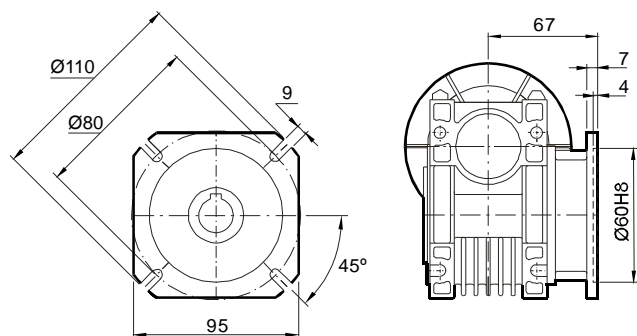

### NMRV040..FB

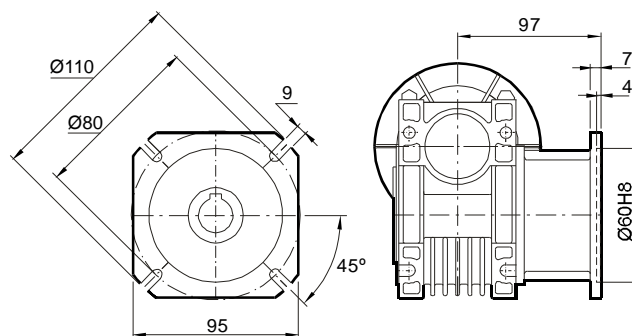

### NMRV040..FC

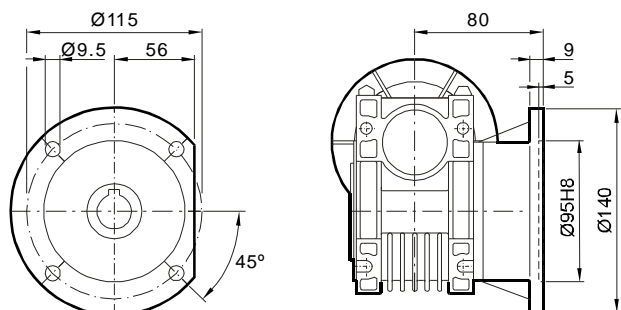

### NMRV040..FD

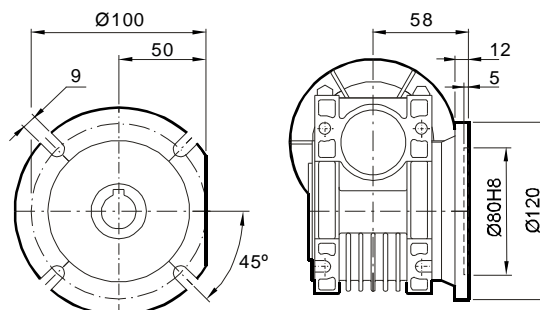

### 注意:

- 1 输入法兰尺寸详见76页;
- 2 减速器重量约2.3KG;
- 3 铝合金箱体;
- 4 括号内尺寸按需生产。

### ATTENTION

- 1 input flange dimensions shown on page 76;
- 2 worm gear reducer approximable weight 2.3 kg;
- 3 aluminium housing;
- 4 bracket dimensions on request .





## 安装尺寸

## Mounting Dimensions

### NMRV050..

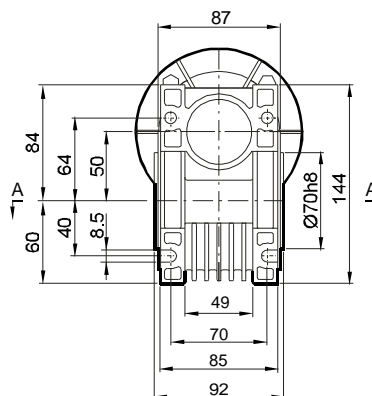
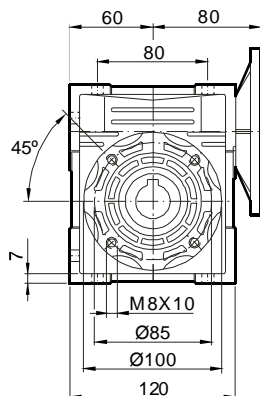

### NMRV050..VS

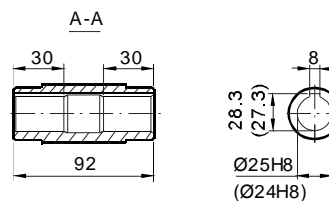
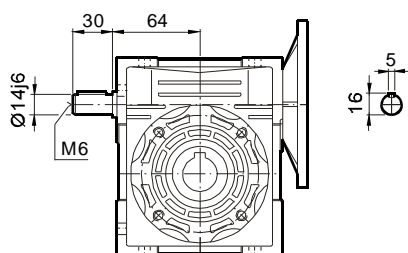

### NMRV050..FA

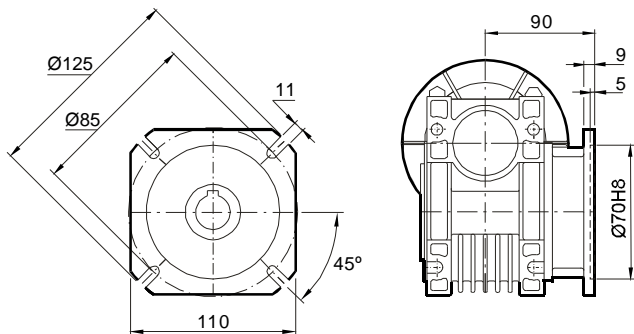

### NMRV050..FB

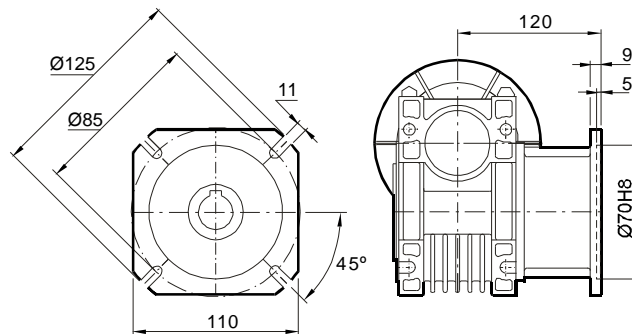

### NMRV050..FC

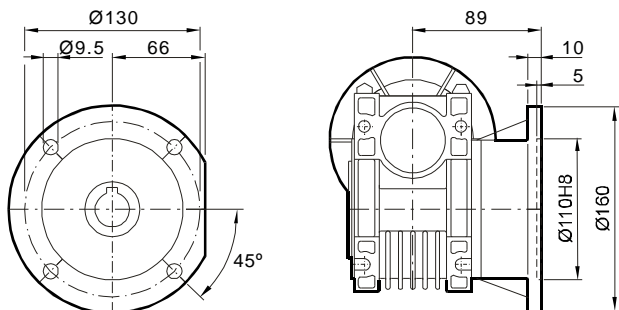

### NMRV050..FD

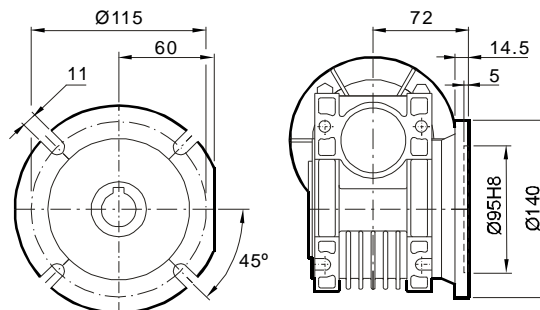

### 注意:

- 1 输入法兰尺寸详见76页;
- 2 减速器重量约3.5KG;
- 3 铝合金箱体;
- 4 括号内尺寸按需生产.

### ATTENTION

- 1 input flange dimensions shown on page 76;
- 2 worm gear reducer approximable weight 3.5 kg;
- 3 aluminium housing;
- 4 bracket dimensions on request .



## 安装尺寸

## Mounting Dimensions

### NMRV063..

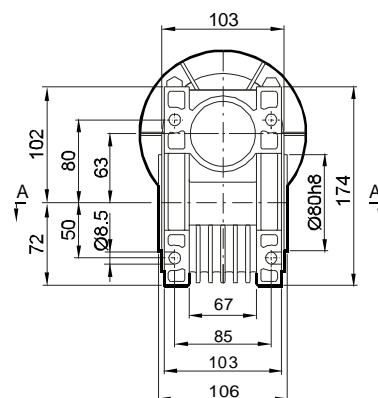
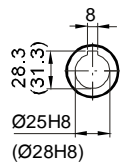
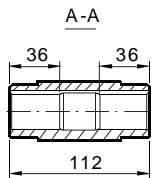
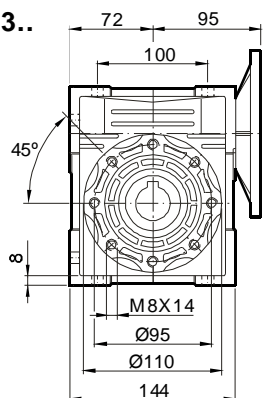

### NMRV063..VS

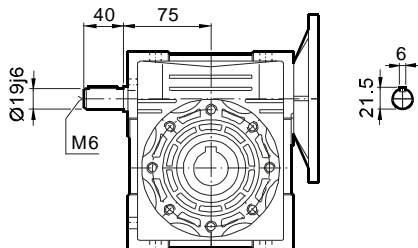

### NMRV063..FA

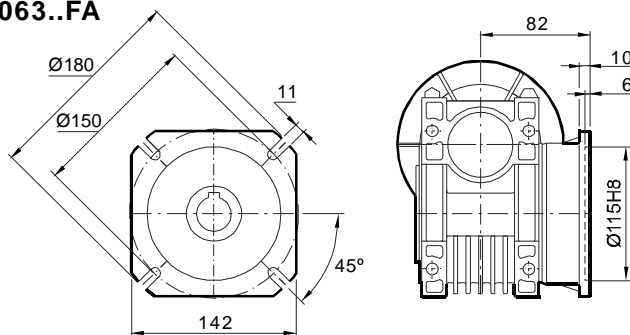

### NMRV063..FB

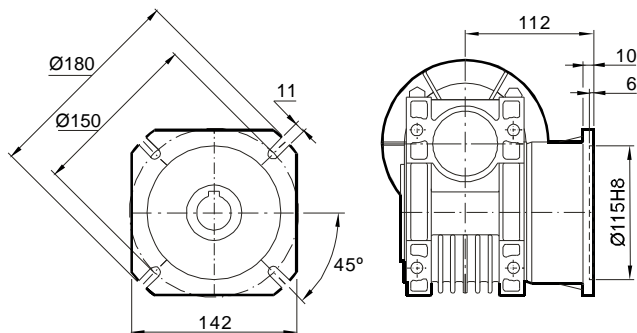

### NMRV063..FC

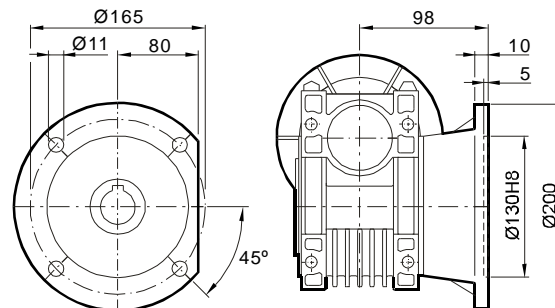

### NMRV063..FD

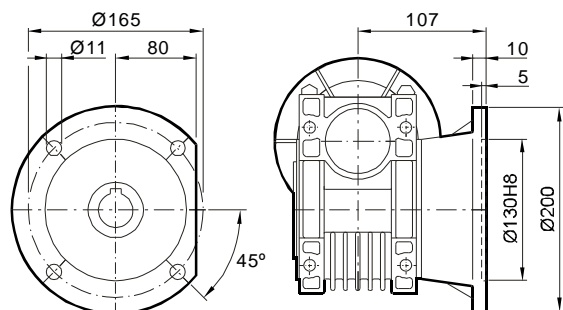

### NMRV063..FE

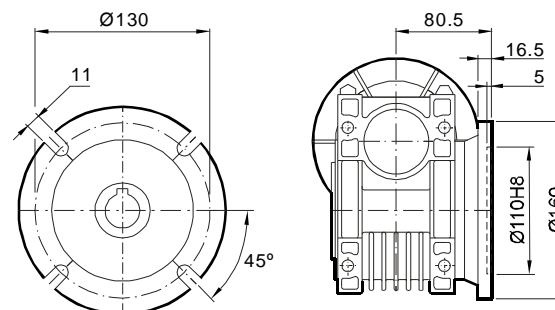

### 注意:

- 1 输入法兰尺寸详见76页;
- 2 减速器重量约6.2KG;
- 3 铝合金箱体;
- 4 括号内尺寸按需生产.

### ATTENTION

- 1 input flange dimensions shown on page 76;
- 2 worm gear reducer approximable weight 6.2 kg;
- 3 aluminium housing;
- 4 bracket dimensions on request .



## 安装尺寸

## Mounting Dimensions

### NMRV075..

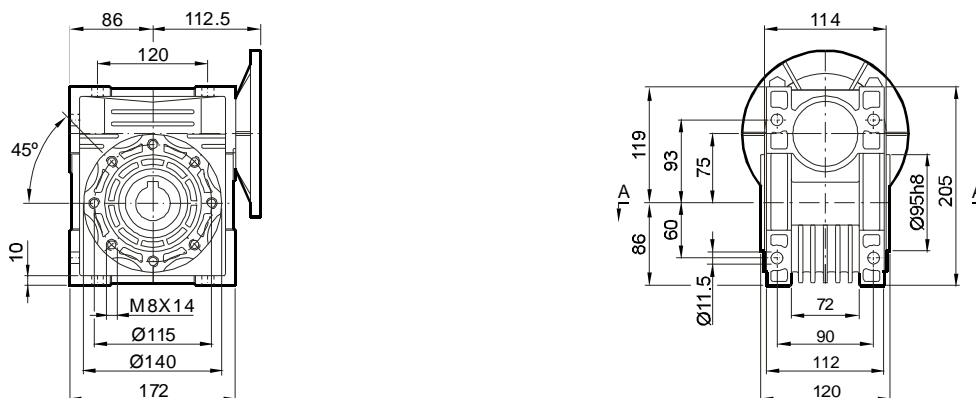

### NMRV075..VS

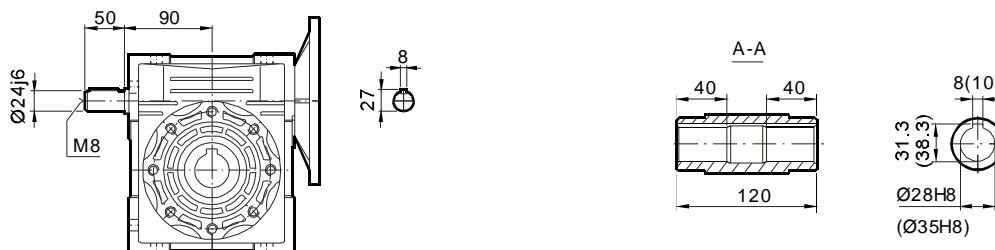

### NMRV075..FA

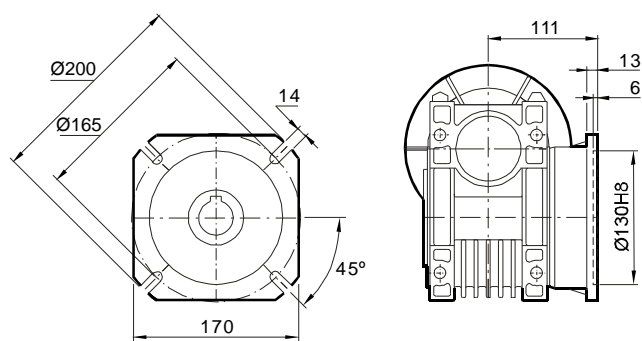

### NMRV075..FB

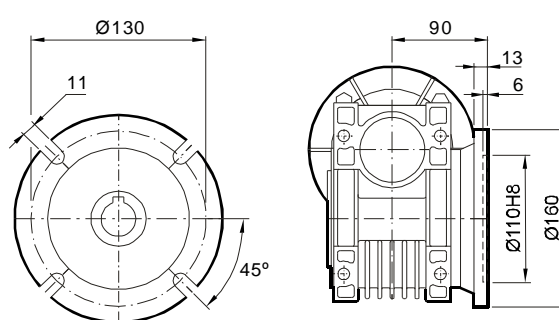

### 注意:

- 1 输入法兰尺寸详见76页;
- 2 减速器重量约9KG;
- 3 铝合金箱体;
- 4 括号内尺寸按需生产。

### ATTENTION

- 1 input flange dimensions shown on page 76;
- 2 worm gear reducer approximable weight 9 kg;
- 3 aluminium housing;
- 4 bracket dimensions on request .



## 安装尺寸

## Mounting Dimensions

### NMRV090..

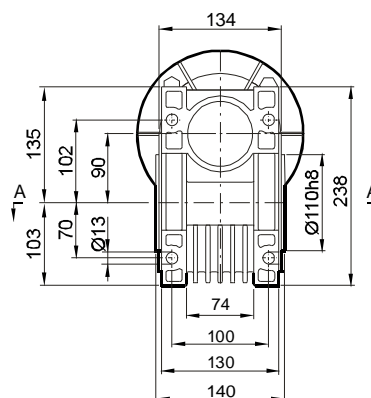
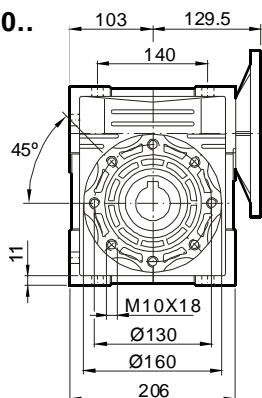

### NMRV090..VS

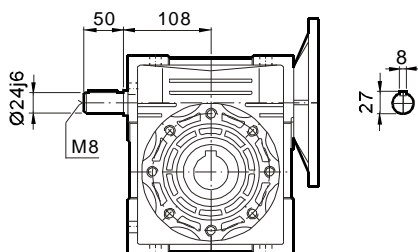

A-A

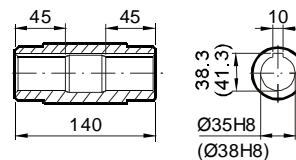

### NMRV090..FA

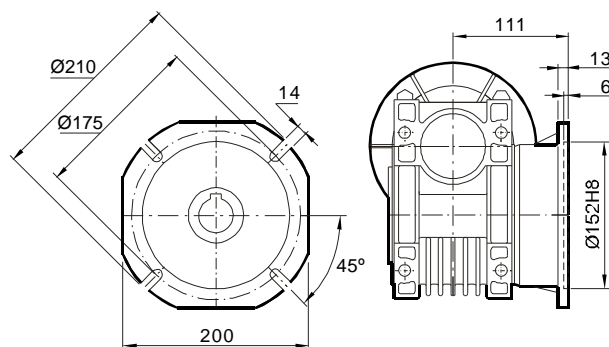

### NMRV090..FB

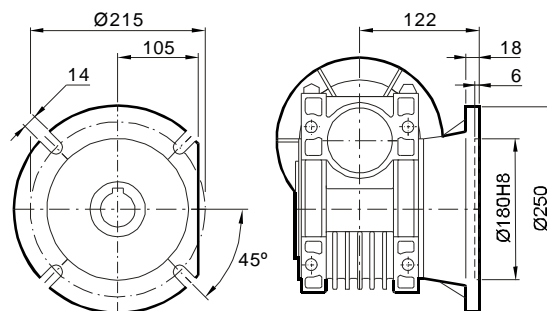

### NMRV090..FC

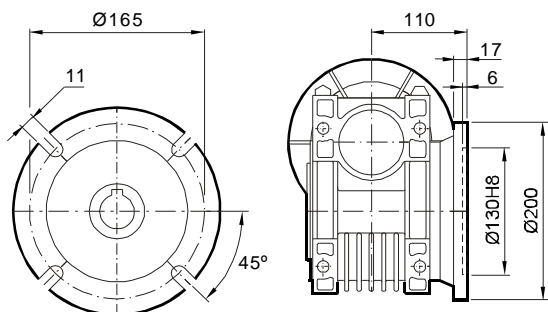

### NMRV090..FD

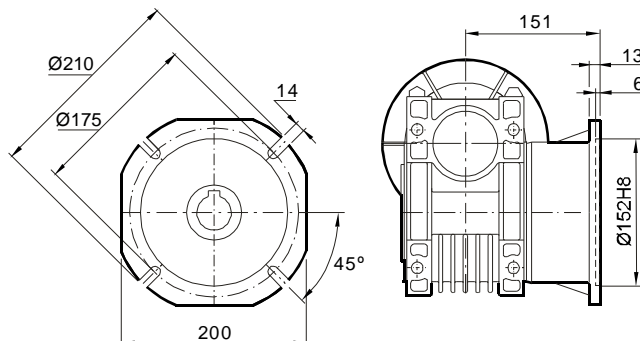

注意:

- 1 输入法兰尺寸详见76页;
- 2 减速器重量约13KG;
- 3 铝合金箱体;
- 4 括号内尺寸按需生产。

ATTENTION

- 1 input flange dimensions shown on page 76;
- 2 worm gear reducer approximable weight 13 kg;
- 3 aluminium housing;
- 4 bracket dimensions on request .



安装尺寸

Mounting Dimensions

NMRV110..

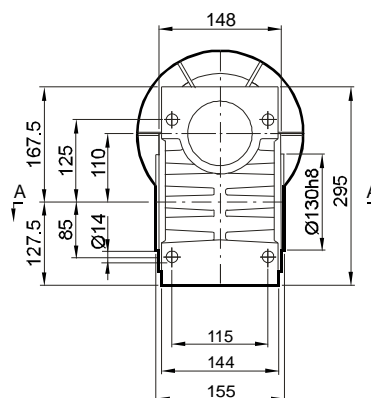
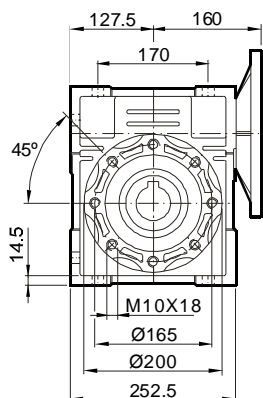

NMRV110..VS

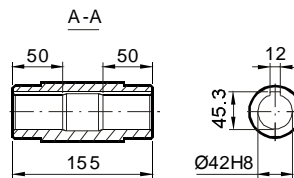
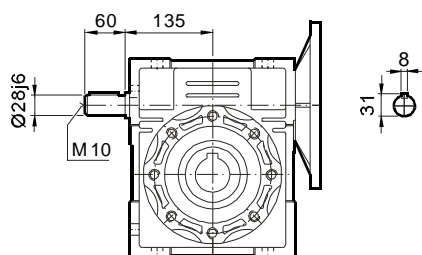

NMRV110..FA

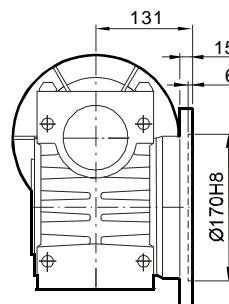
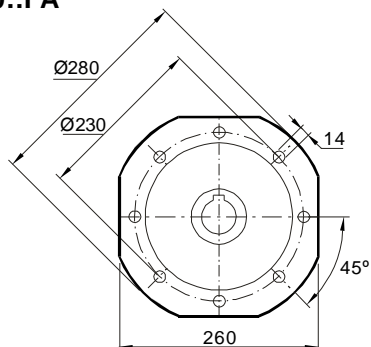

注意:

- 1 输入法兰尺寸详见76页;
- 2 减速器重量约35KG;
- 3 铸铁箱体。

ATTENTION

- 1 input flange dimensions shown on page 76;
- 2 worm gear reducer approximable weight 35 kg;
- 3 casting iron housing.



安装尺寸

Mounting Dimensions

NMRV130..

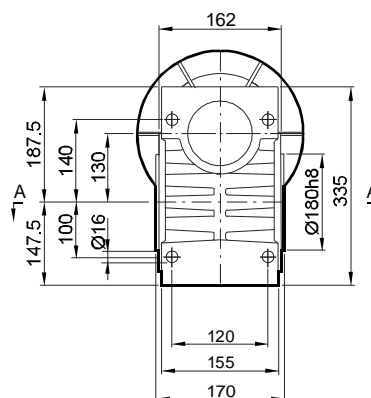
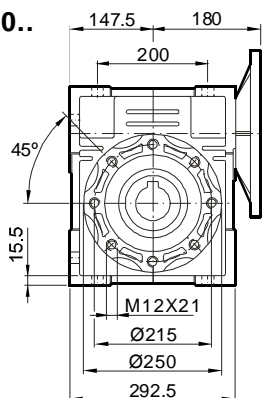

NMRV130..VS

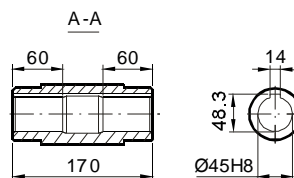
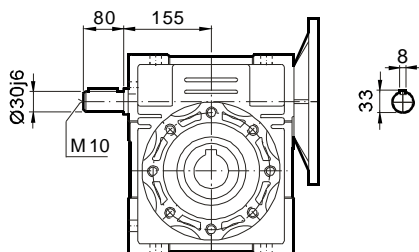

NMRV130..FA

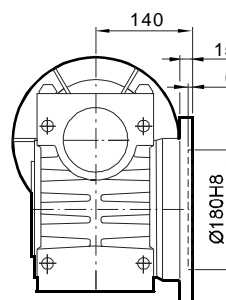
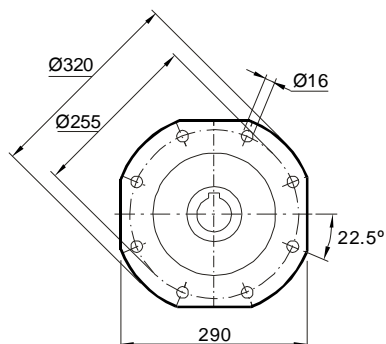

注意:

- 1 输入法兰尺寸详见76页;
- 2 减速器重量约48KG;
- 3 铸铁箱体。

ATTENTION

- 1 input flange dimensions shown on page 76;
- 2 worm gear reducer approximable weight 48 kg;
- 3 casting iron housing.



## 安装尺寸

## Mounting Dimensions

### NMRV150..

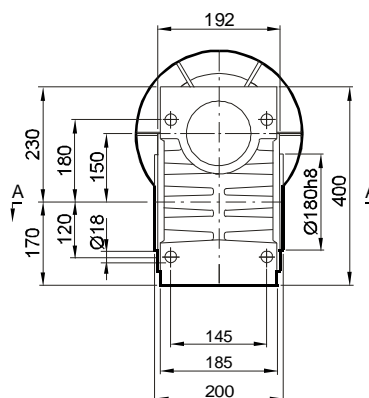
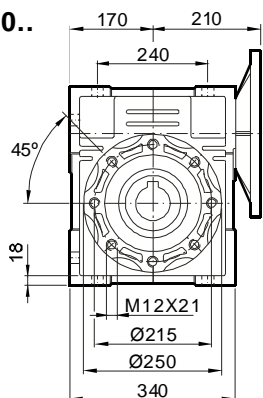

### NMRV150..VS

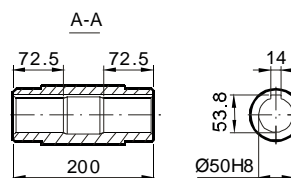
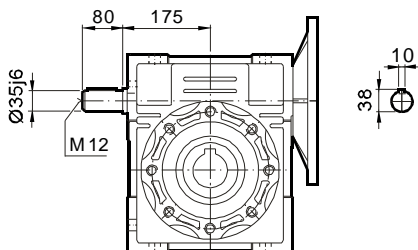

### NMRV150..FA

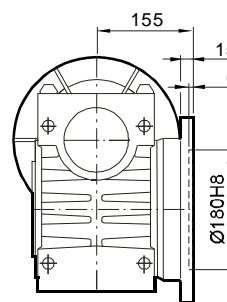
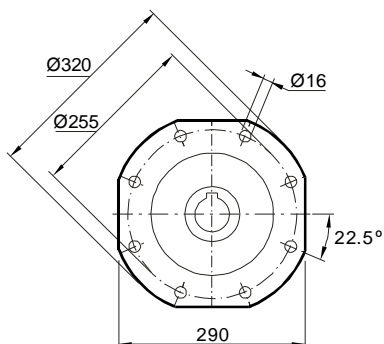

### 注意:

- 1 输入法兰尺寸详见76页;
- 2 减速器重量约84KG;
- 3 铸铁箱体。

### ATTENTION

- 1 input flange dimensions shown on page 76;
- 2 worm gear reducer approximable weight 84 kg;
- 3 casting iron housing.



安装尺寸

Mounting Dimensions

NMRV040+PC063..

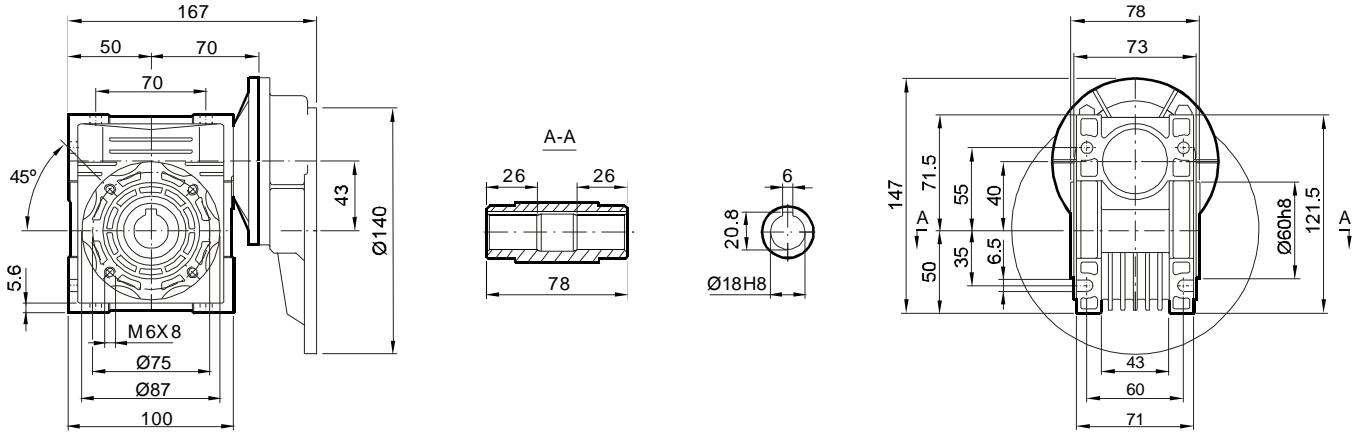

NMRV050+PC063..

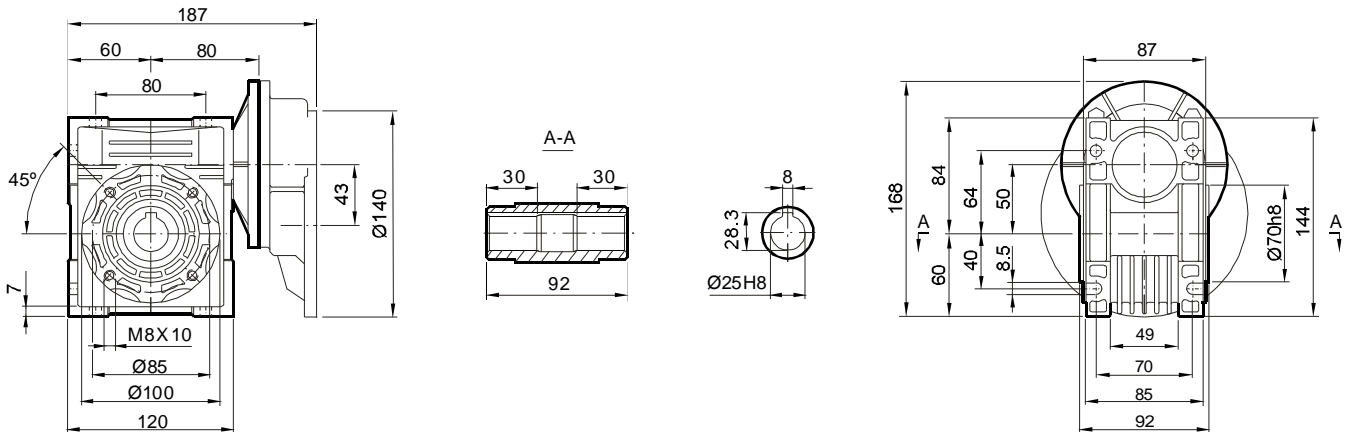

NMRV050+PC071..

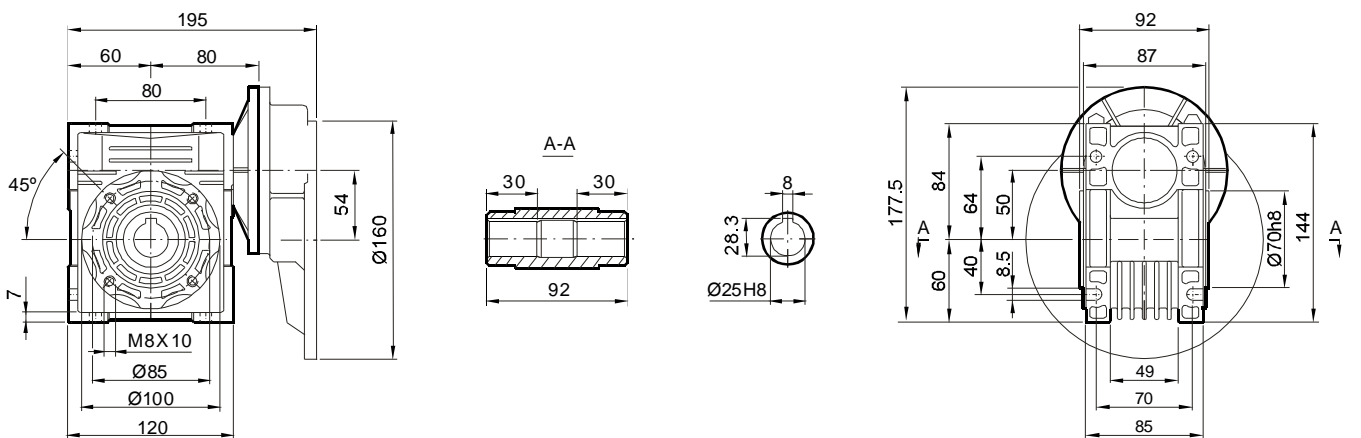

注意:

- 1 输出法兰尺寸, 详见对应的NMRV机型;
- 2 延伸轴尺寸, 详见对应的NMRV机型;

ATTENTION

- 1 for output flange dimensions, consider relevant NMRV size;
- 2 for extensional worm shaft, consider relevant NMRV size;





安装尺寸

Mounting Dimensions

NMRV063+PC063..

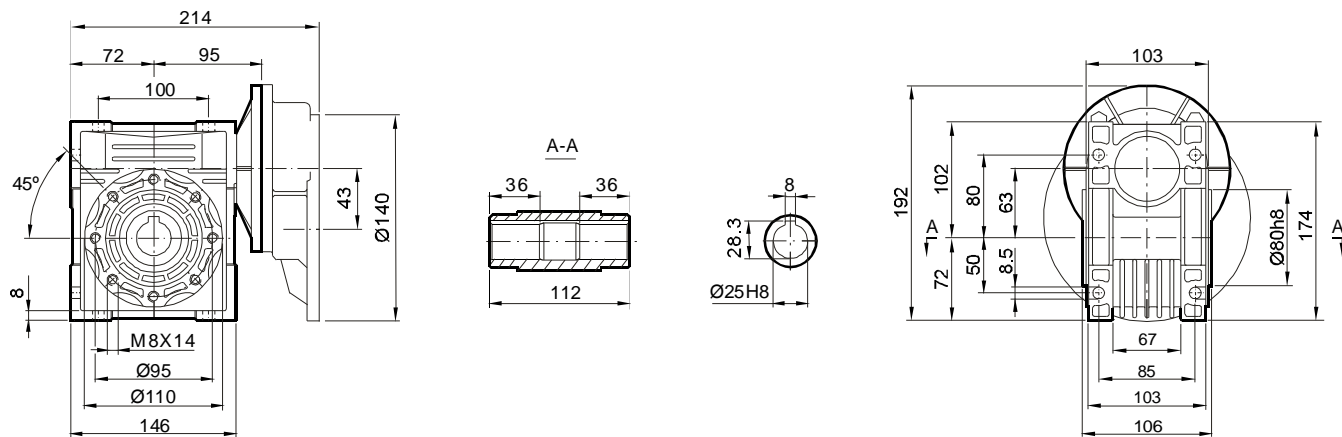

NMRV063+PC071..

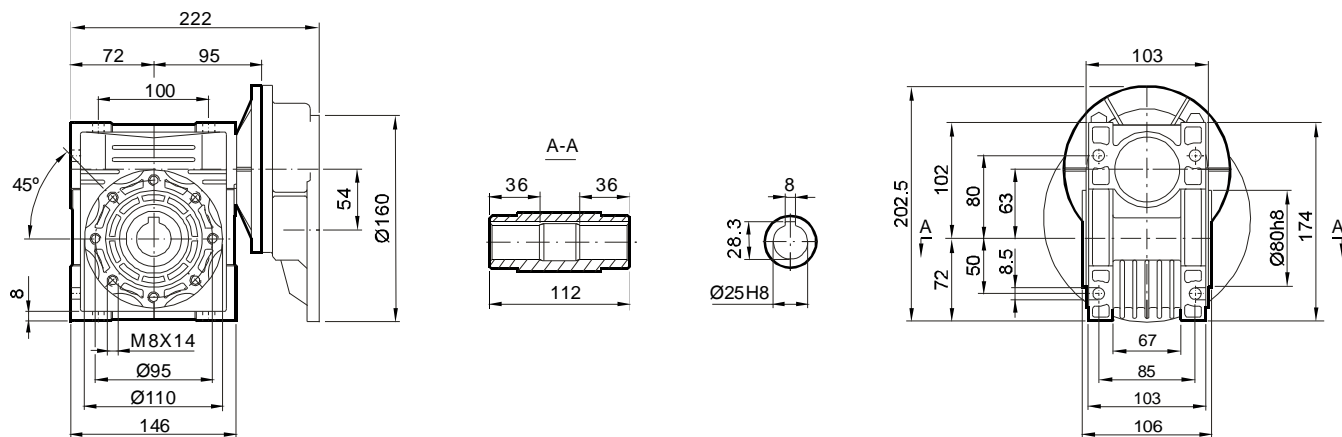

NMRV075+PC071..

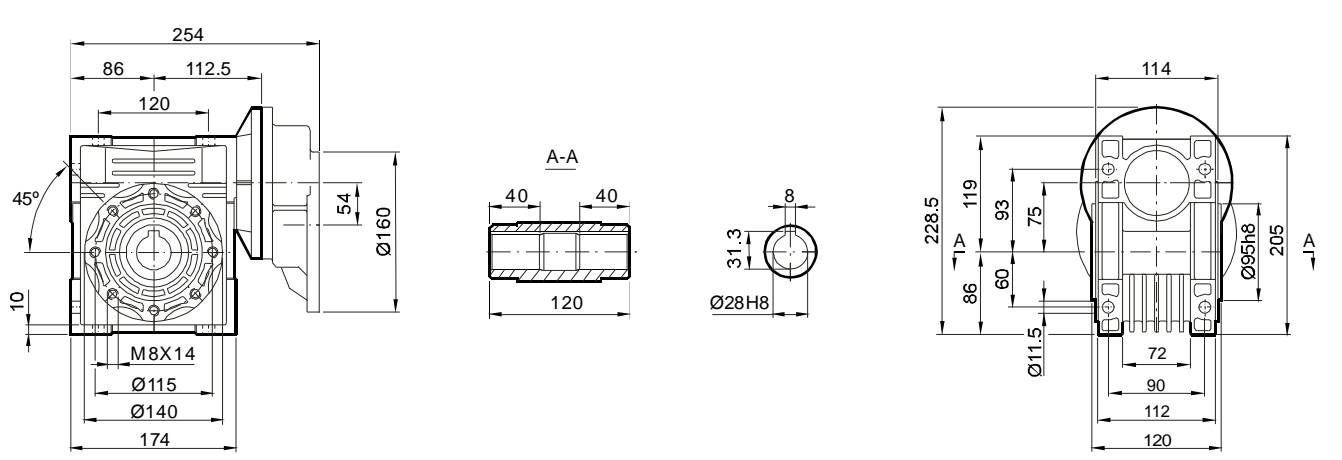

注意:

- 1 输出法兰尺寸, 详见对应的NMRV机型;
- 2 延伸轴尺寸, 详见详见对应的NMRV机型;

ATTENTION

- 1 for output flange dimensions, consider relevant NMRV size;
- 2 for extensional worm shaft, consider relevant NMRV size;



安装尺寸

Mounting Dimensions

NMRV075+PC080..

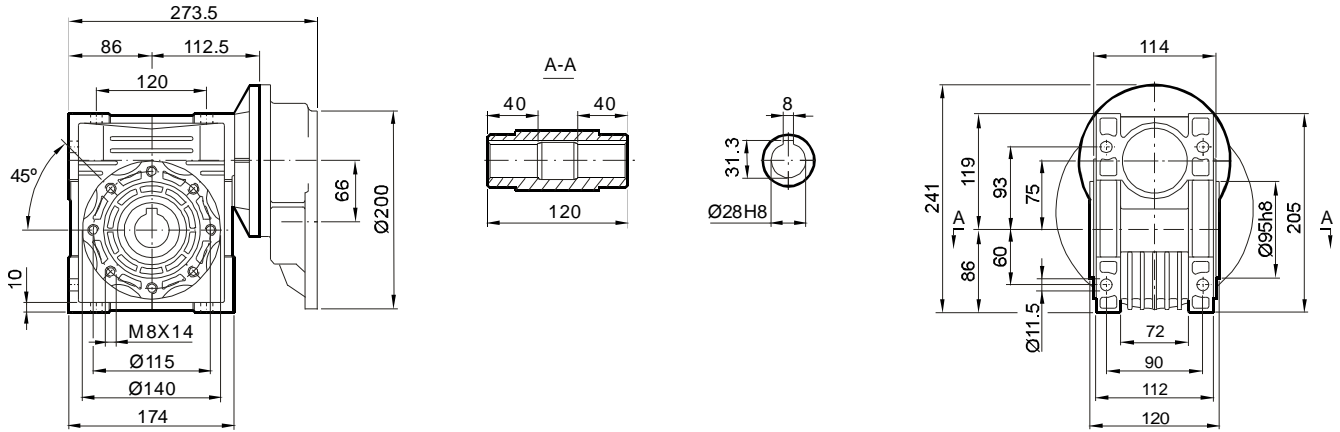

NMRV090+PC071..

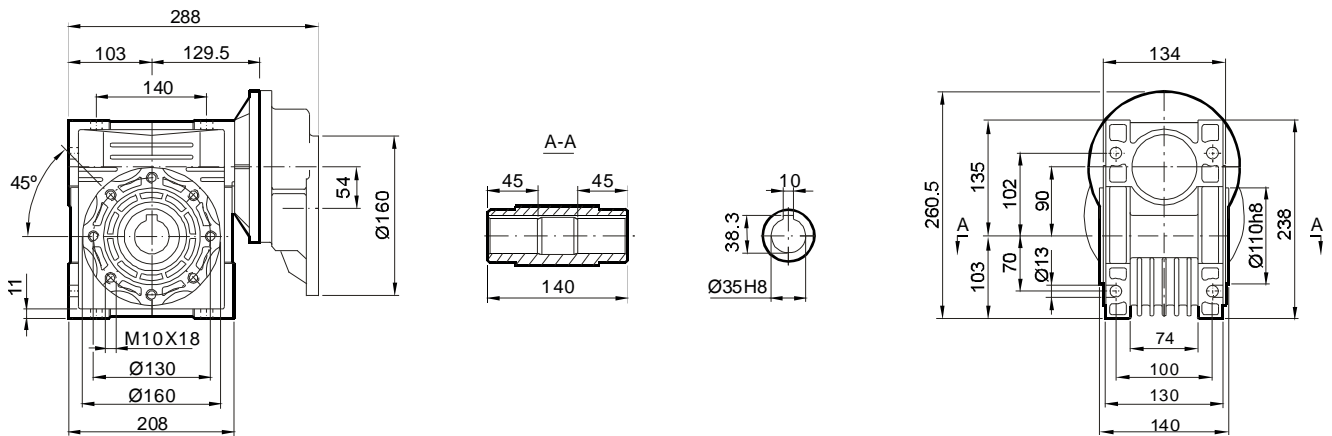

NMRV090+PC080..

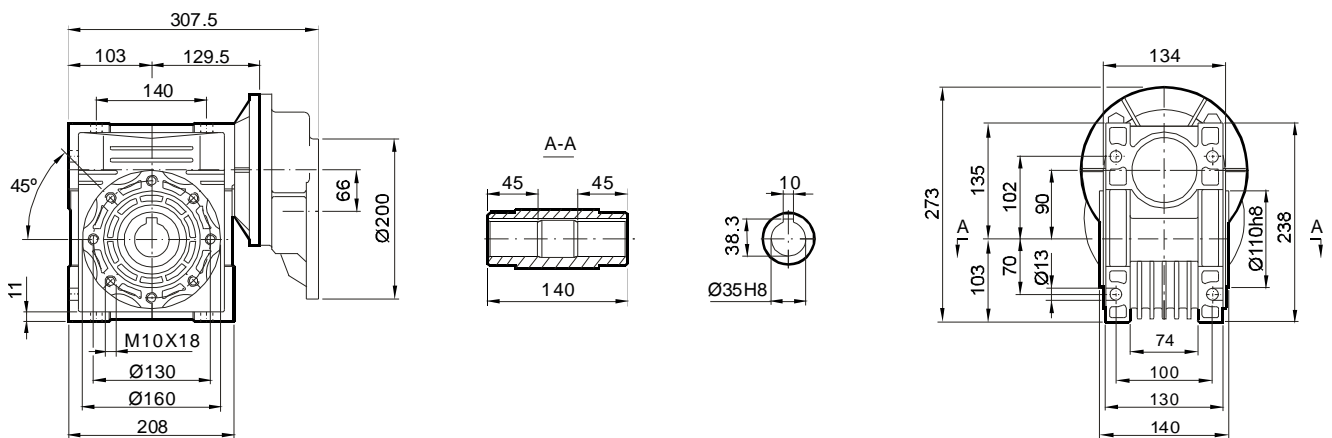

注意:

- 1 输出法兰尺寸, 详见对应的NMRV机型;
- 2 延伸轴尺寸, 详见对应的NMRV机型;

ATTENTION

- 1 for output flange dimensions, consider relevant NMRV size;
- 2 for extensional worm shaft, consider relevant NMRV size;



安装尺寸

Mounting Dimensions

NMRV110+PC080..

NMRV110+PC090..

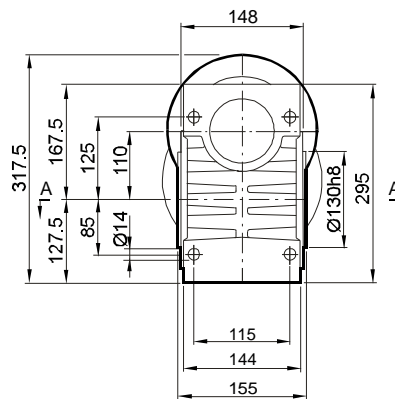
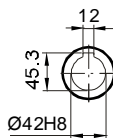
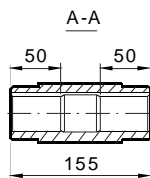
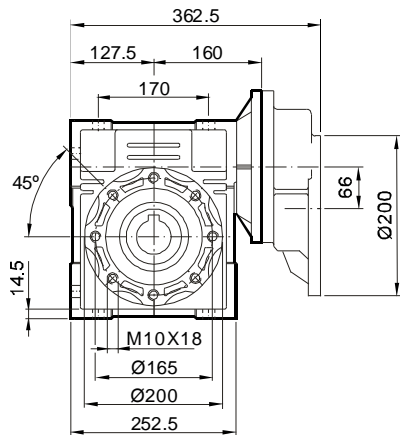

NMRV130+PC080..

NMRV130+PC090..

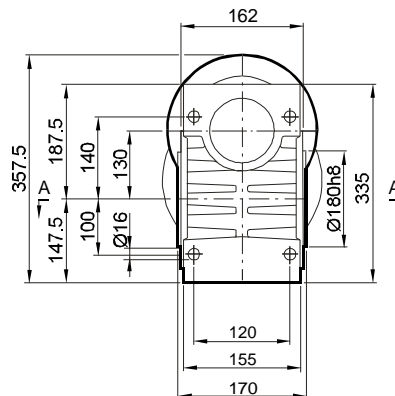
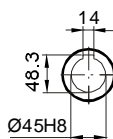
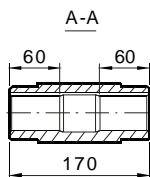
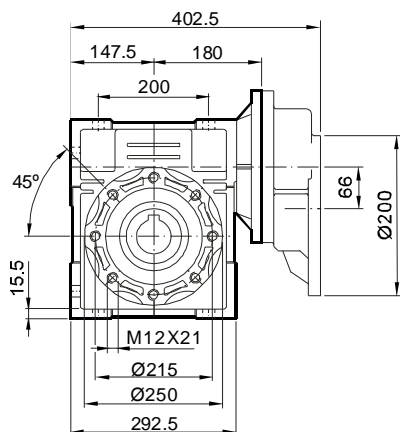

注意:

- 1 输出法兰尺寸, 详见对应的NMRV机型;
- 2 延伸轴尺寸, 详见对应的NMRV机型;

ATTENTION

- 1 for output flange dimensions, consider relevant NMRV size;
- 2 for extensional worm shaft, consider relevant NMRV size;



## 安装尺寸

## Mounting Dimensions

### NMRV025/030

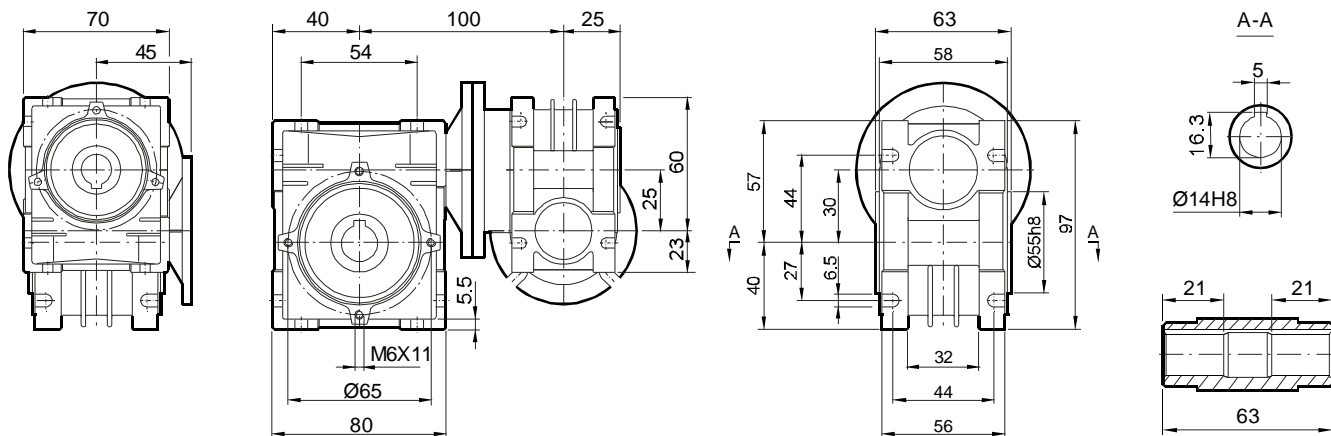

### NMRV025/040

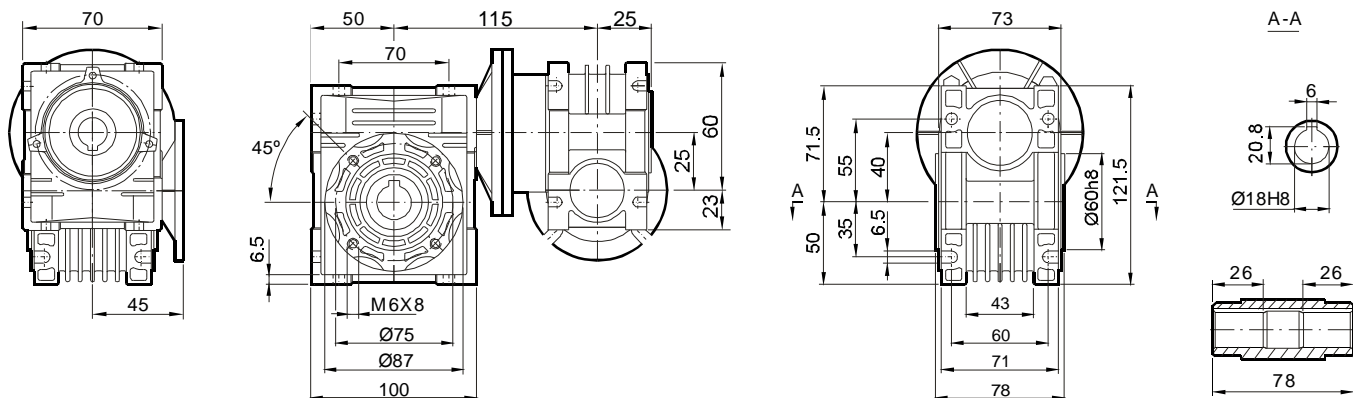

### NMRV030/040

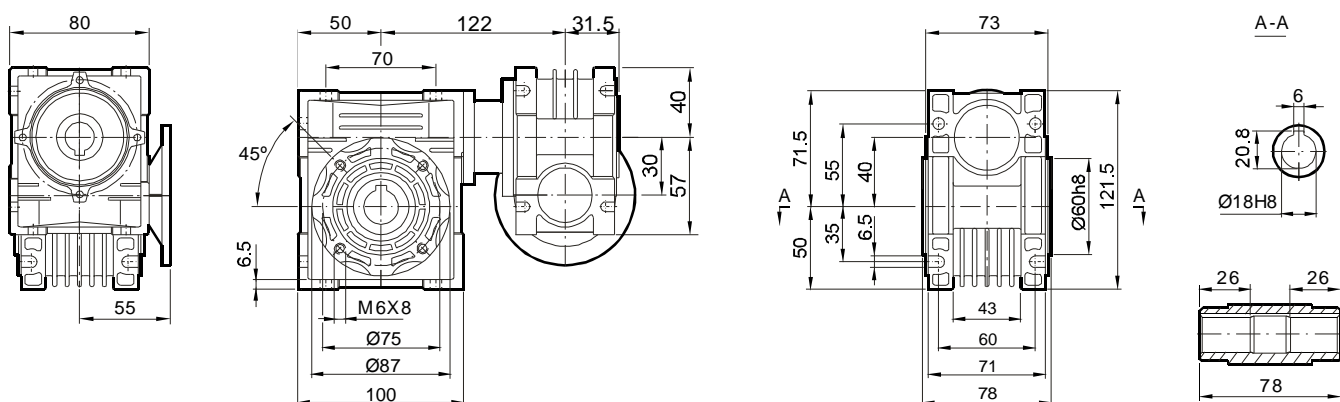

#### 注意:

- 1 输出法兰尺寸, 详见对应的NMRV机型;
- 2 延伸轴尺寸, 详见详见对应的NMRV机型;

#### ATTENTION

- 1 for output flange dimensions, consider relevant NMRV size;
- 2 for extensional worm shaft, consider relevant NMRV size;



## 安装尺寸

## Mounting Dimensions

### NMRV030/050

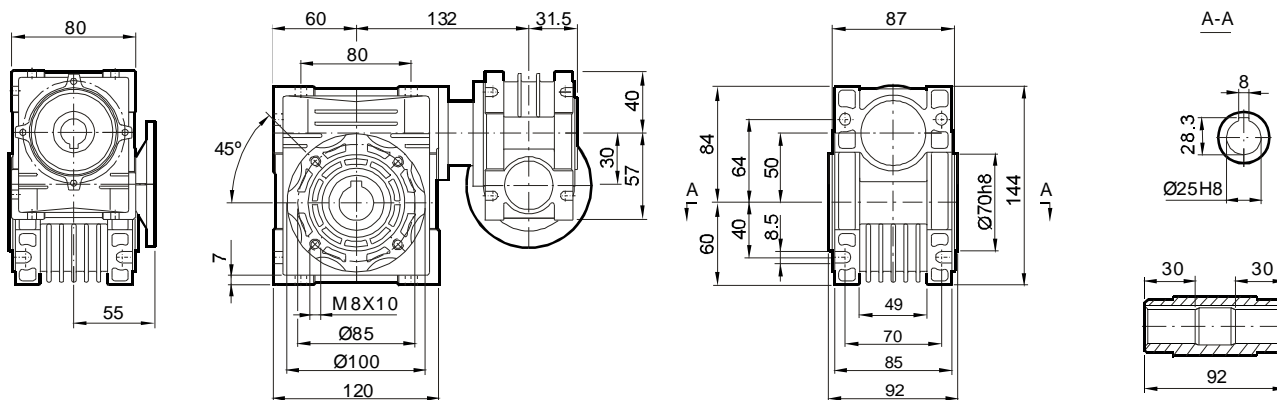

### NMRV030/063

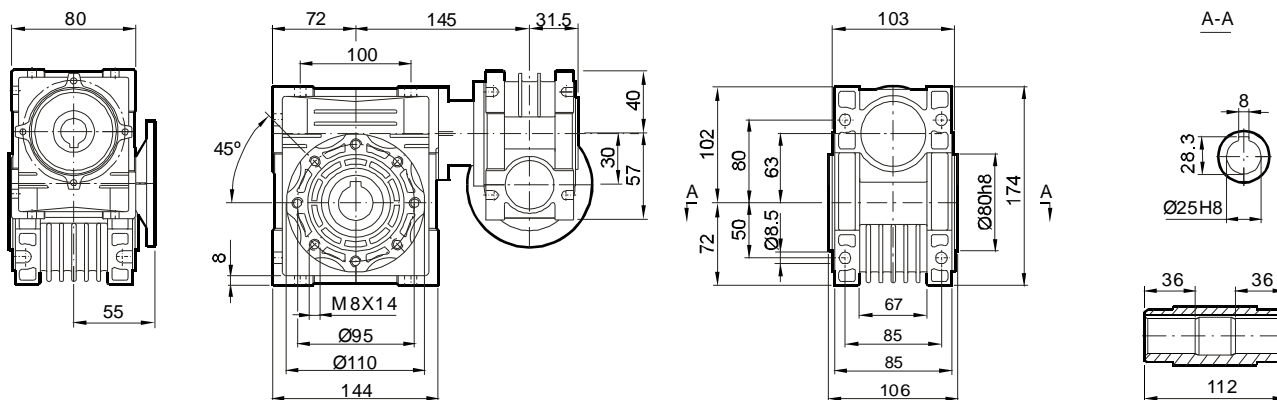

### NMRV040/075

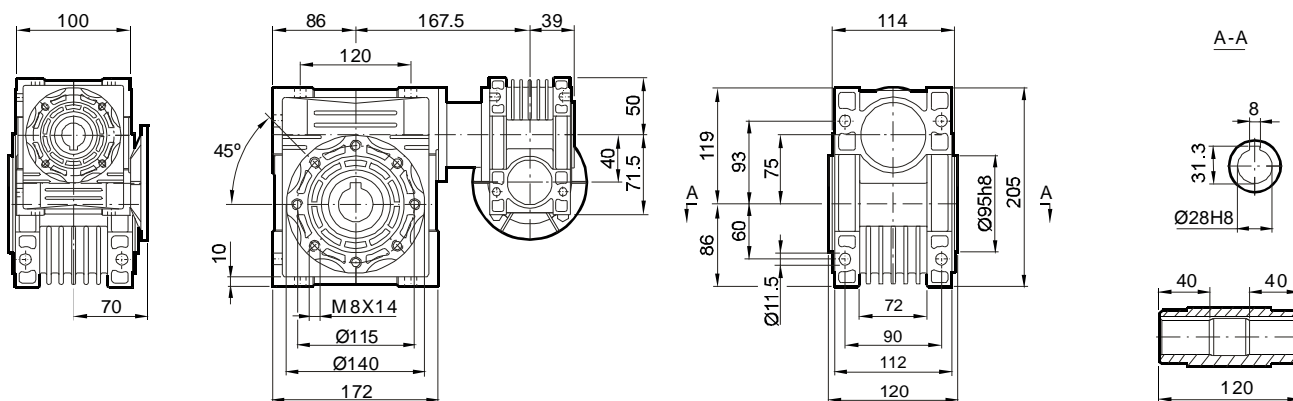

### 注意:

- 1 输出法兰尺寸, 详见对应的NMRV机型;
- 2 延伸轴尺寸, 详见对应的NMRV机型;

### ATTENTION

- 1 for output flange dimensions, consider relevant NMRV size;
- 2 for extensional worm shaft, consider relevant NMRV size;



## 安装尺寸

## Mounting Dimensions

### NMRV040/090

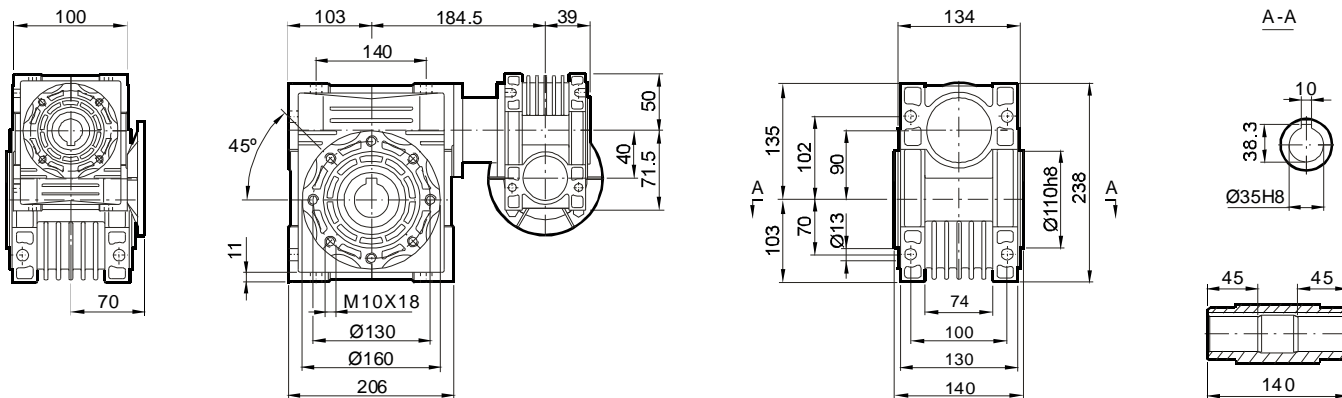

### NMRV050/110

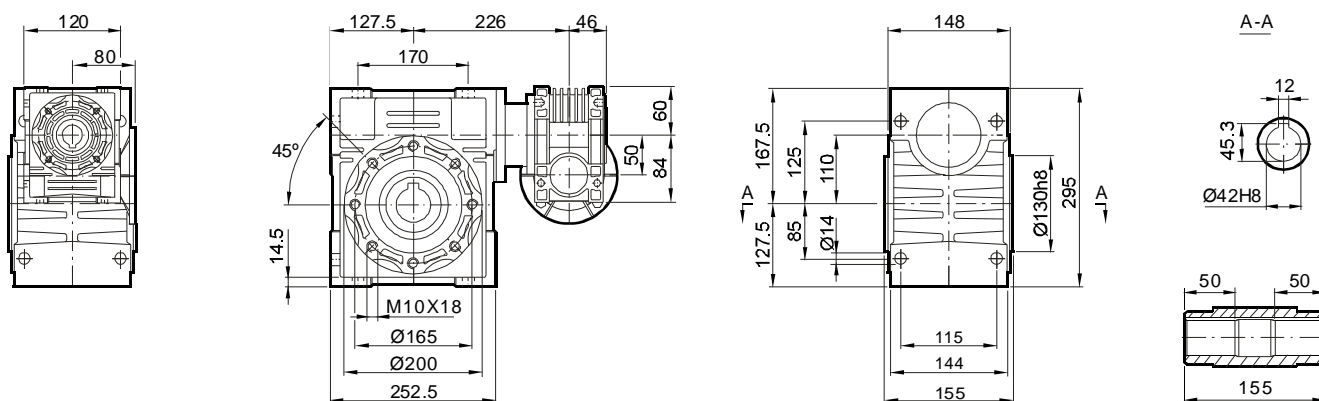

### NMRV063/130

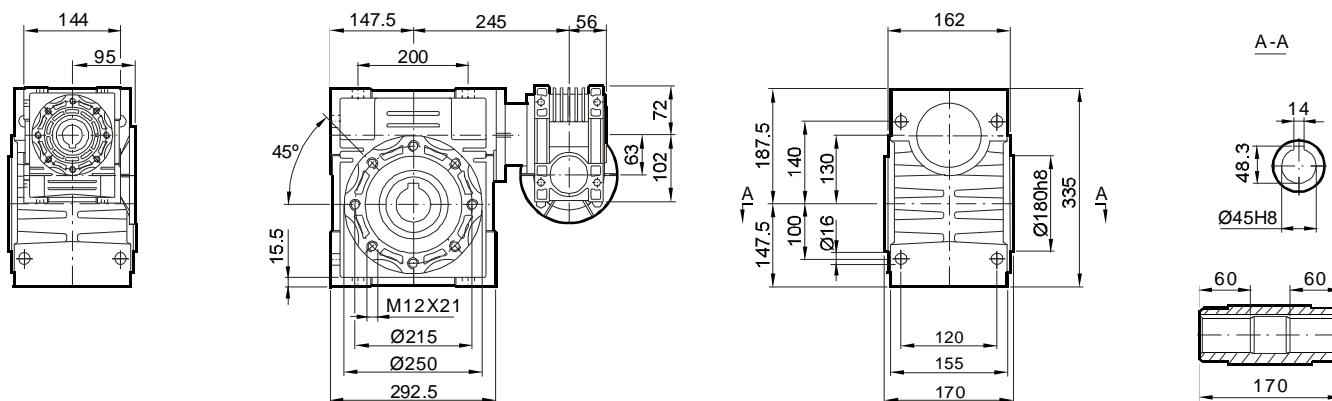

#### 注意:

- 1 输出法兰尺寸, 详见对应的NMRV机型;
- 2 延伸轴尺寸, 详见对应的NMRV机型;

#### ATTENTION

- 1 for output flange dimensions, consider relevant NMRV size;
- 2 for extensional worm shaft, consider relevant NMRV size;



安装尺寸

Mounting Dimensions

**NMRV063/150**

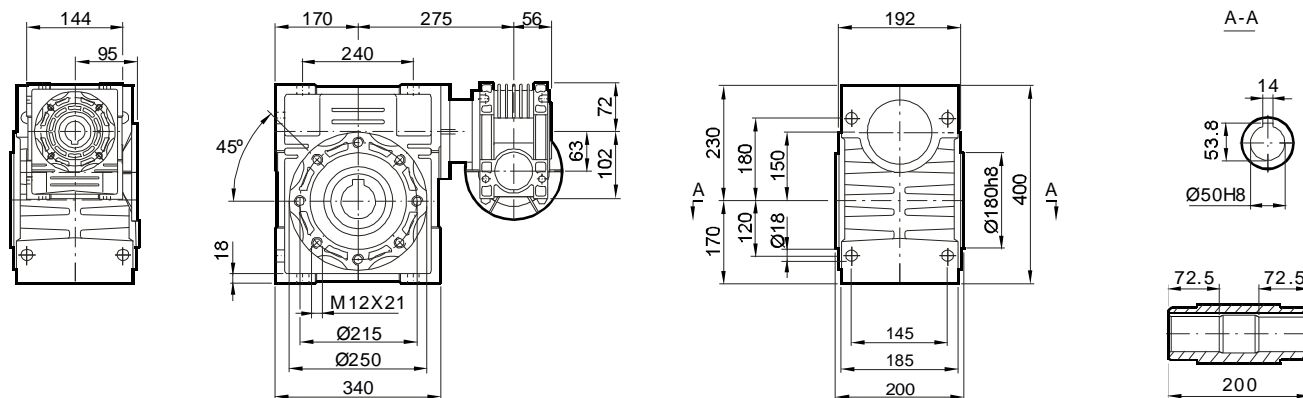

注意:

- 1 输出法兰尺寸, 详见对应的NMRV机型;
- 2 延伸轴尺寸, 详见对应的NMRV机型;

**ATTENTION**

- 1 for output flange dimensions, consider relevant NMRV size;
- 2 for extensional worm shaft, consider relevant NMRV size;

附加单向及双向输出轴

**Additional Single & Double Shaft**

**NMRV..AS**

**NMRV..AB**

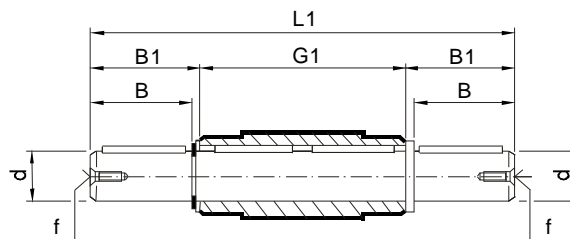
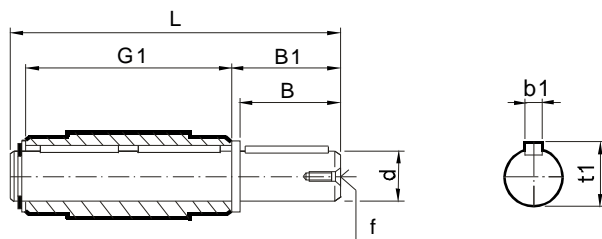

	d	B	B1	G1	L	L1	f	b1	t1
<b>025</b>	11g6	23	25.5	50	81	101	-	4	12.5
<b>030</b>	14 h6	30	32.5	63	102	128	M6	5	16
<b>040</b>	18 h6	40	43	78	128	164	M6	6	20.5
<b>050</b>	25 h6	50	53.5	92	153	199	M10	8	28
<b>063</b>	25 h6	50	53.5	112	173	219	M10	8	28
<b>075</b>	28 h6	60	63.5	120	192	247	M10	8	31
<b>090</b>	35 h6	80	84.5	140	234	309	M12	10	38
<b>110</b>	42 h6	80	84.5	155	249	324	M16	12	45
<b>130</b>	45 h6	80	85	170	265	340	M16	14	48.5
<b>150</b>	50 h6	82	87	200	297	374	M16	14	53.5



安装尺寸

Mounting Dimensions

附加扭力臂

Additional Torque Arm

**NMRV..TA**

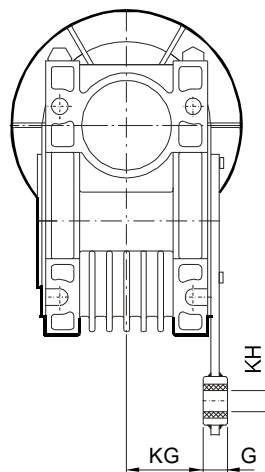
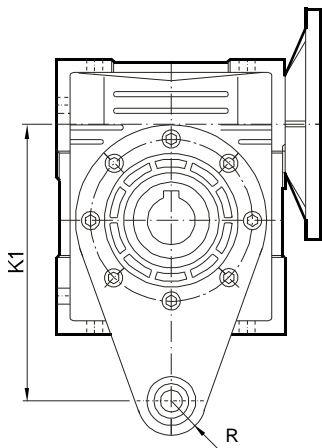

	<b>K1</b>	<b>G</b>	<b>KG</b>	<b>KH</b>	<b>R</b>
<b>025</b>	70	14	17.5	8	15
<b>030</b>	85	14	24	8	15
<b>040</b>	100	14	31.5	10	18
<b>050</b>	100	14	38.5	10	18
<b>063</b>	150	14	49	10	18
<b>075</b>	200	25	47.5	20	30
<b>090</b>	200	25	57.5	20	30
<b>110</b>	250	30	62	25	35
<b>130</b>	250	30	69	25	35
<b>150</b>	250	30	84	25	35





安装尺寸

Mounting Dimensions

NRV输入轴尺寸

NRV Input shaft Dimensions

NRV..

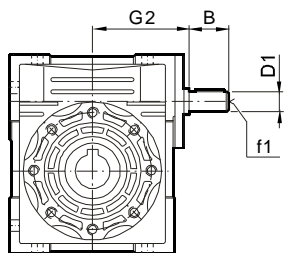

NRV..VS

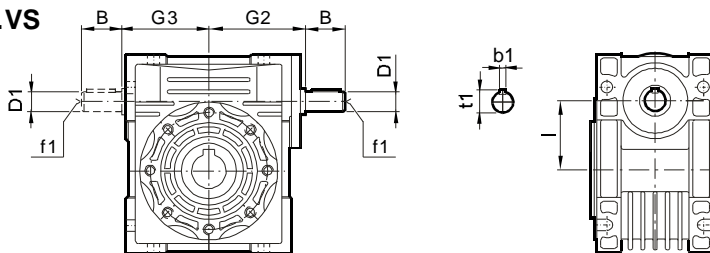

NRV	030	040	050	063	075	090	110	130	150
<b>B</b>	20	23	30	40	50	50	60	80	80
<b>D1</b>	9j6	11j6	14j6	19j6	24j6	24j6	28j6	30j6	35j6
<b>G2</b>	51	60	74	90	105	125	142	162	195
<b>G3</b>	45	53	64	75	90	108	135	155	175
<b>l</b>	30	40	50	63	75	90	110	130	150
<b>b1</b>	3	4	5	6	8	8	8	8	10
<b>f1</b>	-	-	M6	M6	M8	M8	M10	M10	M12
<b>t1</b>	10,2	12,5	16	21,5	27	27	31	33	38

NRV-NMRV

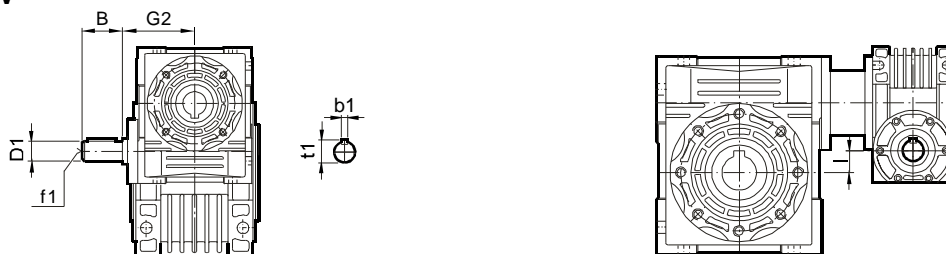

NRV-NMRV	030-040	030-050	030-063	040-075	040-090	050-110	063-130	063-150
<b>B</b>	20	20	20	23	23	30	40	40
<b>D1</b>	9j6	9j6	9j6	11j6	11j6	14j6	19j6	19j6
<b>G2</b>	51	51	51	60	60	74	90	90
<b>l</b>	10	20	33	35	50	60	67	87
<b>b1</b>	3	3	3	4	4	5	6	6
<b>f1</b>	-	-	-	-	-	M6	M6	M6
<b>t1</b>	10,2	10,2	10,2	12,5	12,5	16	21,5	21,5

注意:

- 1 输出法兰尺寸, 详见对应的NMRV机型;
- 2 延伸轴尺寸, 详见对应的NMRV机型;

ATTENTION

- 1 for output flange dimensions, consider relevant NMRV size;
- 2 for extensional worm shaft, consider relevant NMRV size;



安装尺寸

Mounting Dimensions

电机输入法兰与减速比的匹配

机型号, 电机法兰与减速比的匹配关系见下表

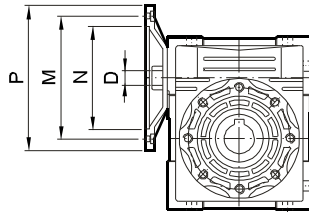

Possible Physical combinations

the following table show which combinations of IEC input flange and the gear ratio range

NMRV	PAM IEC	N	M	P	D											
					5	7.5	10	15	20	25	30	40	50	60	80	100
025	56B14	50	65	80	9	9	9	9	9	-	9	9	9	9	-	-
030	63B5	95	115	140	11	11	11	11	11	11	11	11	11	-	-	-
	63B14	60	75	90	11	11	11	11	11	11	11	11	11	-	-	-
	56B5	80	100	120	9	9	9	9	9	9	9	9	9	9	9	-
	56B14	50	65	80	9	9	9	9	9	9	9	9	9	9	9	-
040	71B5	110	130	160	14	14	14	14	14	14	14	14	-	-	-	-
	71B14	70	85	105	14	14	14	14	14	14	14	14	-	-	-	-
	63B5	95	115	140	11	11	11	11	11	11	11	11	11	11	11	11
	63B14	60	75	90	11	11	11	11	11	11	11	11	11	11	11	11
	56B5	80	100	120	-	-	-	-	-	-	-	-	9	9	9	9
050	80B5	130	165	200	19	19	19	19	19	19	19	-	-	-	-	-
	80B14	80	100	120	19	19	19	19	19	19	19	-	-	-	-	-
	71B5	110	130	160	14	14	14	14	14	14	14	14	14	14	14	-
	71B14	70	85	105	14	14	14	14	14	14	14	14	14	14	14	-
	63B5	95	115	140	-	-	-	-	-	-	-	11	11	11	11	11
063	90B5	130	165	200	-	24	24	24	24	24	24	-	-	-	-	-
	90B14	95	115	140	-	24	24	24	24	24	24	-	-	-	-	-
	80B5	130	165	200	-	19	19	19	19	19	19	19	19	19	-	-
	80B14	80	100	120	-	19	19	19	19	19	19	19	19	19	-	-
	71B5	110	130	160	-	-	-	-	-	-	-	14	14	14	14	14
	71B14	70	85	105	-	-	-	-	-	-	-	14	14	14	14	14
075	100/112B5	180	215	250	-	28	28	28	-	-	-	-	-	-	-	-
	100/112B14	110	130	160	-	28	28	28	-	-	-	-	-	-	-	-
	90B5	130	165	200	-	24	24	24	24	24	24	24	-	-	-	-
	90B14	95	115	140	-	24	24	24	24	24	24	24	-	-	-	-
	80B5	130	165	200	-	-	-	-	19	19	19	19	19	19	19	19
	80B14	80	100	120	-	-	-	-	19	19	19	19	19	19	19	19
	71B5	110	130	160	-	-	-	-	-	-	-	-	14	14	14	14
090	100/112B5	180	215	250	-	28	28	28	28	28	28	-	-	-	-	-
	100/112B14	110	130	160	-	28	28	28	28	28	28	-	-	-	-	-
	90B5	130	165	200	-	24	24	24	24	24	24	24	24	-	-	
	90B14	95	115	140	-	24	24	24	24	24	24	24	24	-	-	
	80B5	130	165	200	-	-	-	-	-	-	-	19	19	19	19	19
	80B14	80	100	120	-	-	-	-	-	-	-	19	19	19	19	19
110	132B5	230	265	300	-	38	38	38	38	-	-	-	-	-	-	-
	100/112B5	180	215	250	-	28	28	28	28	28	28	28	28	-	-	
	90B5	130	165	200	-	-	-	-	-	24	24	24	24	24	24	24
	80B5	130	165	200	-	-	-	-	-	-	-	-	-	-	19	19
130	132B5	230	265	300	-	38	38	38	38	38	38	38	-	-	-	-
	100/112B5	180	215	250	-	-	-	-	-	28	28	28	28	28	28	28
	90B5	130	165	200	-	-	-	-	-	-	-	-	-	-	24	24
150	160B5	250	300	350	-	42	42	42	42	42	-	-	-	-	-	-
	132B5	230	265	300	-	-	-	-	38	38	38	38	38	38	-	-
	100/112B5	180	215	250	-	-	-	-	-	-	-	-	28	28	28	28